

GROUND SOURCE HEAT PUMP MANUAL

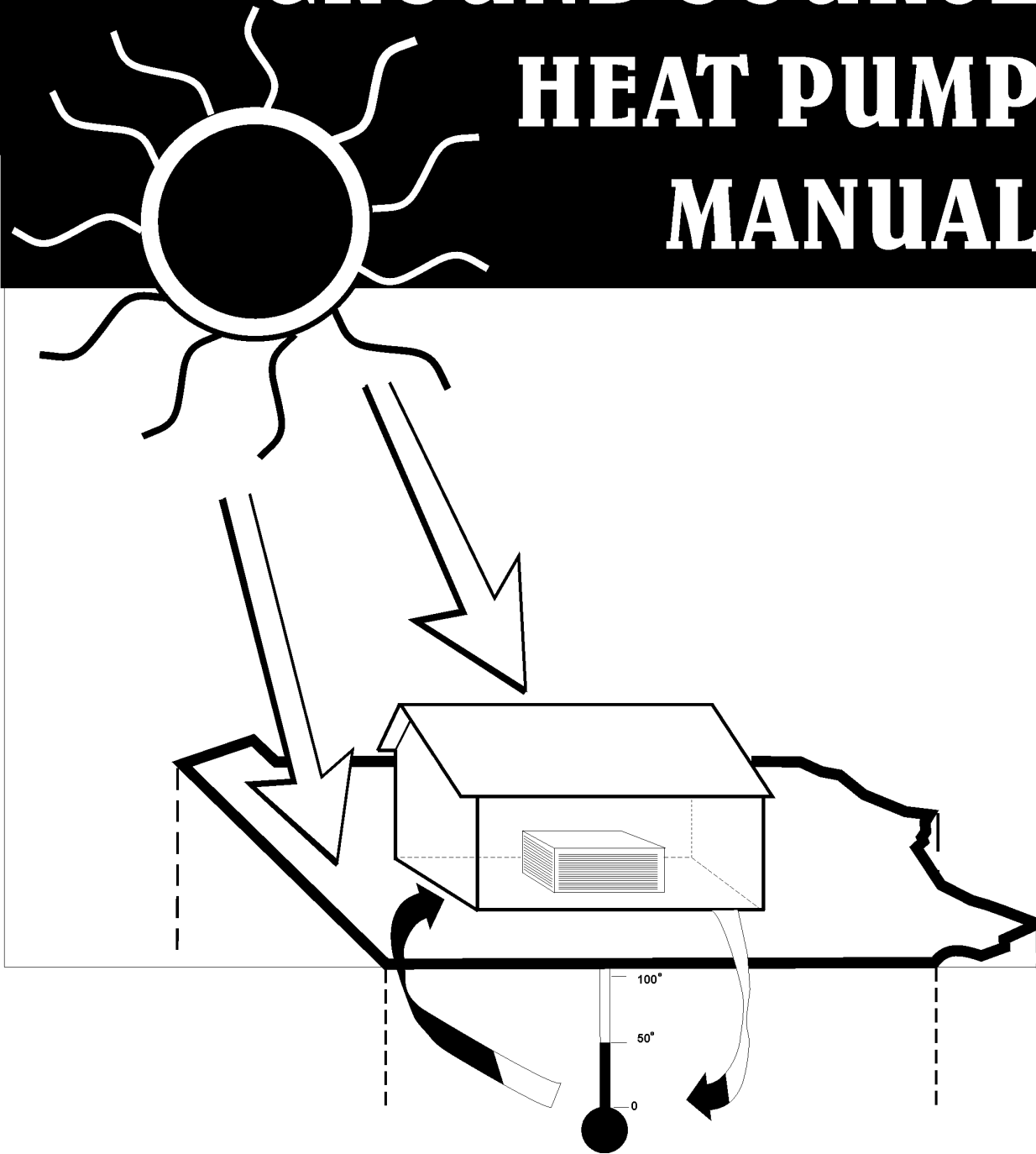

COMMONWEALTH OF PENNSYLVANIA
Department of Environmental Protection

For more information, visit us through the PA PowerPort
at www.state.pa.us or visit DEP directly at www.dep.state.pa.us

**DEPARTMENT OF ENVIRONMENTAL PROTECTION
BUREAU OF WATER SUPPLY MANAGEMENT**

DOCUMENT ID: 383-0300-001

EFFECTIVE DATE: August 23, 2000
Minor changes were made to pages i, 1, 2, 4, 5, 6, 7, 8, 10, 11, 12, 13, 14, 15, 17, 18, 19, 20, 21, 27, 29, 31, 33, 35, 36, 37, 39 and 41 (Dec. 1, 2001)

TITLE: Ground Source Heat Pump Manual

AUTHORITY: Pennsylvania Clean Streams Law (The Clean Stream Law, the Act of June 22, 1937 (P.L. 1987, No. 394), as amended, 35 P.S. 691.1 *et seq.*).

POLICY: This document provides guidance regarding the installation of domestic and commercial ground source heat pump (GSHP) systems.

PURPOSE: This document was developed to provide guidance on the environmental considerations of GSHP systems. A consortium of government and industry is working to increase GSHP unit sales to 400,000 a year by 2005. As the GSHP industry continues to grow, the DEP hopes to avoid potential environmental problems through the use of this manual.

APPLICABILITY: This guidance applies to all local, state and federal agencies and programs with groundwater quality protection responsibilities.

DISCLAIMER: The policies and procedures outlined in this guidance are intended to supplement existing requirements. Nothing in the policies or procedures shall affect regulatory requirements.

The policies and procedures herein are not an adjudication or a regulation. There is no intent on the part of DEP to give the rules in these policies that weight or deference. This document establishes the framework within which DEP will exercise its administrative discretion in the future. DEP reserves the discretion to deviate from this policy statement if circumstances warrant.

PAGE LENGTH: 47 pages

LOCATION: Volume 26, Tab 01D

DEFINITIONS: None

TABLE OF CONTENTS

	PAGE
PREFACE	1
INTRODUCTION	2
1. LEGISLATIVE AND REGULATORY AUTHORITY	3
1.1. GROUNDWATER QUALITY	3
1.2. GROUNDWATER USAGE	3
1.3. FEDERAL REGULATIONS	3
1.3.1. Underground Injection Wells	3
1.3.2. Surface Water Discharges	4
1.4. SYSTEM CONSTRUCTION AND PERMITTING REQUIREMENTS.....	4
1.5. OTHER CONSIDERATIONS	5
2. APPLICATION OF GROUND SOURCE HEAT PUMP SYSTEMS.....	6
2.1. BACKGROUND	6
2.2. PRINCIPLES OF OPERATION	6
2.3. ENERGY USAGE.....	8
2.4. SUBSURFACE VS. SURFACE TEMPERATURES	8
2.5. TYPES OF SYSTEMS.....	8
2.6. ORGANIZATIONS INVOLVED WITH INSTALLATION	9
3. CLOSED-LOOP GSHP SYSTEMS.....	10
3.1. BASIC OPERATION	10
3.2. DIRECT EXCHANGE (DX) SYSTEMS.....	10
3.3. THERMAL BEHAVIOR OF SOILS AND ROCKS.....	10
3.4. CIRCULATING FLUIDS	11

3.5.	TYPE AND AMOUNT OF PIPE	12
3.6.	LOOP CONFIGURATIONS	12
	3.6.1. Horizontal Loops	14
	3.6.2. Vertical Loops	14
3.7.	FLUSHING OF LOOPS.....	15
	3.7.1. Debris Flushing	15
	3.7.2. Air Purging	15
	3.7.3. Pressure Testing.....	15
	3.7.4. Final Charging	15
3.8.	BACKFILLING AND GROUTING.....	15
	3.8.1. Backfilling	16
	3.8.2. Grouting	16
	3.8.2.1. Grout Materials	16
	3.8.2.2. Grouting Procedures.....	17
3.9.	POTENTIAL WATER QUALITY PROBLEMS	18
3.10.	ENVIRONMENTAL CONSIDERATIONS AND RECOMMENDATIONS	18
	3.10.1. Horizontal Loops	19
	3.10.2. Vertical Loops	19
4.	OPEN GROUND SOURCE HEAT PUMP SYSTEMS	20
4.1.	GROUNDWATER AVAILABILITY.....	20
4.2.	BASIC OPERATION	20
4.3.	TYPES OF SYSTEMS.....	21
4.4.	DISPOSAL OF WATER	22
	4.4.1. Surface Disposal.....	22
	4.4.2. Subsurface Disposal	22
	4.4.2.1. Standing Wells	23
	4.4.2.2. Discharge Acceptance by Wells	23
4.5.	LEGAL REQUIREMENTS OF DRILLERS	24
4.6.	POTENTIAL SYSTEM AND WATER QUALITY PROBLEMS	25
	4.6.1. Change in Temperature	25
	4.6.2. Chemical Additives	25
	4.6.3. Machinery Pollutants.....	25
	4.6.4. Sewage Disposal	25
	4.6.5. Chemical Imbalances.....	25
	4.6.6. Overpumping and Well Interference	26
	4.6.7. Land Subsidence	26

4.7.	ENVIRONMENTAL CONSIDERATIONS AND RECOMMENDATIONS	27
4.7.1.	System with Return Well.....	27
4.7.2.	System with Surface Return.....	27
4.7.3.	Well Construction Recommendations	28
5.	COMMERCIAL GSHP SYSTEMS	29
5.1.	TYPES OF SYSTEMS.....	29
5.1.1.	Horizontal Closed Loop.....	29
5.1.2.	Vertical Closed Loop GSHP Systems	29
5.1.3.	Groundwater Heat Pumps.....	30
5.2.	ENVIRONMENTAL CONCERNS	30
5.2.1.	Water Quality	30
5.2.1.1.	Leaks.....	30
5.2.1.2.	Thermal Changes	30
5.2.1.3.	Borings and Trench Installation	31
5.2.2.	Quantity of Groundwater	32
5.2.3.	Geologic Hazards	32
5.3.	ENVIRONMENTAL CLEANUP	32
5.4.	RECOMMENDATIONS	32
6.35	SUMMARY	34
6.1.	GENERAL CONSIDERATIONS	34
6.2.	ADDITIONAL SOURCES OF INFORMATION	35
6.3.	REFERENCES	39
Appendix	41

PREFACE

This manual updates the DEP's Ground Source Heat Pump Manual, dated August 23, 2000. It is intended to provide general guidance and information on the existing methods and types of ground source heat pump systems and their relative environmental efficiency and limitations. This guidance should not be construed as an endorsement of any particular system. Questions or comments may be directed to the following:

Department of Environmental Protection
Bureau of Watershed Management
P.O. Box 8555
Harrisburg, PA 17105-8555
717-787-5259

INTRODUCTION

Variations of ground source heat pump (GSHP) systems are often referred to under many names. These names include geothermal, earth-coupled, geoexchange, water-coupled, groundwater, ground-coupled, closed-loop, coiled, open and water-source heat pump systems. Any type of the GSHP systems can be an environmentally sound energy alternative.

GSHP systems are important options to conventional heating and cooling methods. They can significantly reduce the consumption of fossil fuels by using existing energy within the ground. GSHP systems can be a clean source of energy, with only minimal risk of contamination from their use. In addition, their installation is becoming more price competitive with conventional heating and cooling systems.

GSHP systems can be designed to provide heating (including hot water) and cooling. This dual nature is especially attractive in a state such as Pennsylvania, which often has extreme seasonal variations in temperature. The steady temperatures of the subsurface can offset the seasonal temperature variations by serving as a reservoir of heat in the winter and as a drain of heat in the summer.

The number of GSHP installations will most likely continue to expand; similarly, the stress on natural resources will undoubtedly increase because of a steadily growing population and accompanying commercial development. Such trends make it necessary to monitor activities that can impact the environment. In general, GSHP systems have a low potential for adversely impacting the environment. However, aging, poorly installed, or improperly operated GSHPs increase the risk of system failure. Because of their large size, commercial systems may pose a relatively greater threat to the environment as compared to domestic systems. However, even large systems can typically be installed and operated safely.

The Commonwealth of Pennsylvania does not intend to restrict the use of GSHP systems, but rather desires to promote a safe handling of our natural resources for the benefit of everyone. This can be done by avoiding unnecessary risks of potential contamination and by paying close attention to possible groundwater overuse situations.

The primary purpose of this manual is to provide guidance to potential GSHP system installers and users on the environmental aspects of GSHP systems. Factors are presented that should be considered when determining whether a GSHP system is suitable for a particular situation or user. This manual also contains information on the general design, installation and maintenance of such systems.

1. LEGISLATIVE AND REGULATORY AUTHORITY

1.1. GROUNDWATER QUALITY

A GSHP system can be an acceptable energy method for the heating and cooling of buildings. However, the potential for contamination exists because of their placement into the ground or use of groundwater. DEP's authority to regulate the quality of groundwater is contained in the Pennsylvania Clean Streams Law (The Clean Streams Law, the Act of June 22, 1937 (P.L. 1987, No. 394), as amended, 35 P.S. 691.1 *et seq.*). Requirements for cleanup of contamination are set forth in the Land Recycling and Environmental Remediation Standards Act (Act 2 of 1995, 35 P.S. (Sec.) 6026.101 *et seq.*).

1.2 GROUNDWATER USAGE

The Pennsylvania Clean Streams Law addresses groundwater quality, but other issues relating to quantity and groundwater rights have been left to the courts and common law. A complicated legal history in Pennsylvania has distinguished between 1) groundwater that percolates in an undefined channel and 2) groundwater that flows in a definite underground channel.

The Commonwealth's framework of law regarding the use of percolating groundwater is based on the American Use Rule. Under this legal framework, no liability exists for a landowner's usage of groundwater that results in a problem that was not caused by malicious intent or by negligence. Therefore, landowners may withdraw an unlimited quantity of water for useful or beneficial purposes like a groundwater heat pump (GWHP), even if it results in interference with neighboring wells.

Groundwater that flows in specific "underground streams" has been considered as similar to surface water. The legal framework in Pennsylvania that covers these situations is known as riparian rule, which distinguishes domestic uses from extraordinary uses. No limits are placed on domestic uses, even to the point of source depletion. Limits can be placed on withdrawals for extraordinary purposes (such as agriculture, manufacturing and municipal uses) if the withdrawals are determined by the court to be unreasonable with respect to other landowners. Adjudication of problems on a case-by-case basis may not always maintain that using groundwater for a heat pump is a reasonable use.

Presently, no state regulatory program provides for a comprehensive management of groundwater allocation and withdrawal amounts. However, interstate river basin commissions may exert some regulatory influence over large withdrawals of groundwater. For example, the Susquehanna River Basin Commission (SRBC) and the Delaware River Basin Commission (DRBC) have the authority to limit groundwater withdrawals (generally for amounts over 100,000 gallons per day). River basin commissions have the authority to declare water emergencies and to establish special protection areas. For more information, contact the appropriate commission. The addresses of the river basin commissions that cover Pennsylvania are listed in Section 6.2.

1.3. FEDERAL REGULATIONS

1.3.1 Underground Injection Wells

Return wells for groundwater heat pumps are classified as Class V injection wells by the U.S. EPA. Such wells have been determined not to pose a significant threat to the environment. The role of oversight for these wells has been assigned to state governments; however, the Commonwealth of Pennsylvania does not have primacy for injection wells. EPA requires that owners and operators of injection wells, including those for GWHPs, report at least the following (40 CFR § 144.26):

- facility name and location
- name and address of legal contact
- ownership of the facility
- nature and type of injection well
- operating status of injection well

This information is requested by the U.S. EPA on the national form "Inventory of Injection Wells, OMB No. 158-R0170." See Section 6.2 for contacting EPA.

In Pennsylvania, injection wells (also known as return, recharge or diffusion wells) for this purpose do not require a permit. However, no additives may be placed in the water. Any additives placed in the return water would change the classification to industrial waste. For further information, contact the appropriate DEP regional office, or EPA Region III.

1.3.2. Surface Water Discharges

Water circulated through a GWHP system that will be disposed of to a surface water body may require a National Pollutant Discharge Elimination System (NPDES) permit. The owner should contact the appropriate DEP regional office. (See Appendix)

1.4 SYSTEM CONSTRUCTION AND PERMITTING REQUIREMENTS

The construction quality of the underground portion of a GSHP system is the most critical component for ensuring that the system is environmentally sound. For example, improperly constructed drill holes can become a pathway for contamination. Although Pennsylvania does not have a legal code for construction of private water wells or borings, all wells and borings must be constructed to prevent contamination from occurring or spreading. Contractors who construct wells or borings in such a way as to cause or spread contamination in an aquifer may be held liable.

Act 610 of the Administrative Code, known as the Water Well Drillers License Act, requires that all drillers be licensed and that wells be properly abandoned. Proper abandonment procedures are detailed in Chapter 7 of DEP's Groundwater Monitoring Guidance Manual (3800-TG-3833000001). DEP has also provided guidelines for installing private water wells in bedrock (Fact Sheet 3800-FS-DEP2450). Also, the driller must submit logs and locations of the wells to the Bureau of Topographic and Geologic Survey (see Section 4.5).

GWHP wells that also will be used for human consumption must comply with applicable permit and construction requirements. GWHP wells that will be used for private water supply do not require a permit. GWHP wells that will supply community water (at least 15 service connections or 25 people serviced throughout the year) will require a DEP permit. GWHP wells that will serve as noncommunity water systems (serving more than 25 non-residential people) generally do not require a permit. However, the operator must file a Brief Description Form with the DEP regional office of the Bureau of Water Supply Management. Certain construction and design standards will be applicable. Also, if the groundwater is treated beyond disinfection, a permit will be required. For more information, see DEP document 383-2100-208. New or modified community system wells are required to own or control a Zone 1 protection area (having a radius of 100 to 400 feet around the well) in order to prohibit activities that may adversely affect the source (See PA Bulletin, Vol. 24, No. 41, October 8, 1994).

Local governments can impose specific well or GSHP system construction requirements. For example, Chester and Montgomery Counties have developed regulations on water well construction for private and semi-public wells. An ordinance in Upper Saucon Township in Lehigh County requires a permit for construction of a GSHP system and prohibits horizontal systems in the delineated environmentally sensitive

zone. Contractors or system owners should inquire about relevant regulations and ordinances from the local governments.

1.5 OTHER CONSIDERATIONS

Individual communities or water suppliers may voluntarily establish "Wellhead Protection Areas." Such areas can be approved by DEP if they contain the necessary criteria (PA Bulletin, Vol. 24, No. 41, October 8, 1994). The criteria include identifying potential sources of contamination and approaches to protect the groundwater source (such as through ordinances or design standards). System owners and installers of GSHP systems should confer with local government authorities about any wellhead protection areas. Water suppliers and local governments may take a proactive approach to potential contamination of a groundwater supply by establishing an approved wellhead protection. For more information, contact the DEP, Bureau of Watershed Management at (717) 787-5259.

Another environmental concern is the association of chlorofluorocarbons (CFCs) and hydrochlorofluorocarbons (HCFCs) with the depletion of the ozone protective layer in the upper atmosphere. R-22, an HCFC, is the refrigerant that is used in all GSHP systems. Closed-loop GSHP systems with the plastic pipe use considerably less HCFCs than direct exchange, air to air or central air conditioner systems. The refrigerant is also factory installed and sealed and the systems are operated indoors. These characteristics help to limit the release of HCFCs to the environment. As of July 1, 1992, technicians who work with CFCs and HCFCs must recapture the refrigerant gases. The production of CFCs ended in 1995. These provisions are part of the 1990 Clean Air Act.

The GSHP industry is relatively young, highly variable and growing fast. Consequently, those who are involved in this industry or who will use GSHP systems should watch for developments of new technology and techniques. See Section 6.2 for more information and industry contacts.

Equipment used in the installation of GSHP systems should have certification seals for safety and certified performance. These certifications are found on all equipment intended for mainstream customers.

2. APPLICATION OF GROUND SOURCE HEAT PUMP SYSTEMS

GSHP systems can be grouped into two types: closed-loop and open systems. The closed-loop systems circulate a fluid through a subsurface loop of pipe and then to the heat pump. Open systems (groundwater heat pump systems) circulate groundwater to the heat pump and then discharge it.

Ground source heat pumps are most often used for residential and commercial space heating and cooling. GSHP technology is also used to generate hot water for domestic and industrial applications.

2.1. BACKGROUND

The technique of applying a heat pump to a subsurface energy source has existed for over 50 years and the technology of the heat pump has existed for over a 100 years. Before the 1970s, GSHP systems were few in number. However, many types of energy systems grew in popularity and prominence as a result of the oil shortages in the 1970s. Contractors and homebuilders developed substantial interest in the heat pump. Although the promotion of energy alternatives slowed in the 1980s, the development of GSHP systems expanded.

Closed-loop systems emerged in the early 1980s. Even in regions of abundant groundwater, these systems are now being installed. Significant improvements in technology such as fused joints, polyethylene pipe and more efficient heat pumps have made these systems competitive with conventional heating and cooling systems. A wide variety of GSHP systems are now available for the consumer. Continued improvements in technology and efficiency throughout the 1990s have increased energy savings and lowered installation and maintenance costs.

The United States General Accounting Office report *Geothermal Energy: Outlook Limited for Some Uses but Promising for Geothermal Heat Pumps* states that "Geothermal heat pumps are the most energy-efficient means of heating and cooling buildings in most areas of the United States." The Energy Policy Act of 1992 contained provisions to encourage the use of geothermal systems as alternative energy sources. In response to the President's Climate Change Action Plan, the Geothermal Heat Pump Consortium in cooperation with the U.S. EPA and the Department of Energy is working to reduce greenhouse gases and increase GSHP unit sales to 400,000 annually by the year 2005.

2.2 PRINCIPLES OF OPERATION

GSHPs take advantage of the natural heat stored underground. Using the same technology as does a refrigerator, a heat pump can move heat taken from the ground and apply it to a building. The process can also be reversed and the subsurface can be used as a drain for a building's excess heat.

The basic working principle of the heat pump (Figure 1) is that evaporation is a cooling process. When a substance evaporates (changes from a liquid to a gas), heat is absorbed into the gas. A common example is the evaporation of moisture from your skin. Heat is absorbed into the air which cools your body.

FIGURE 1: BASIC COMPONENTS OF A HEAT PUMP

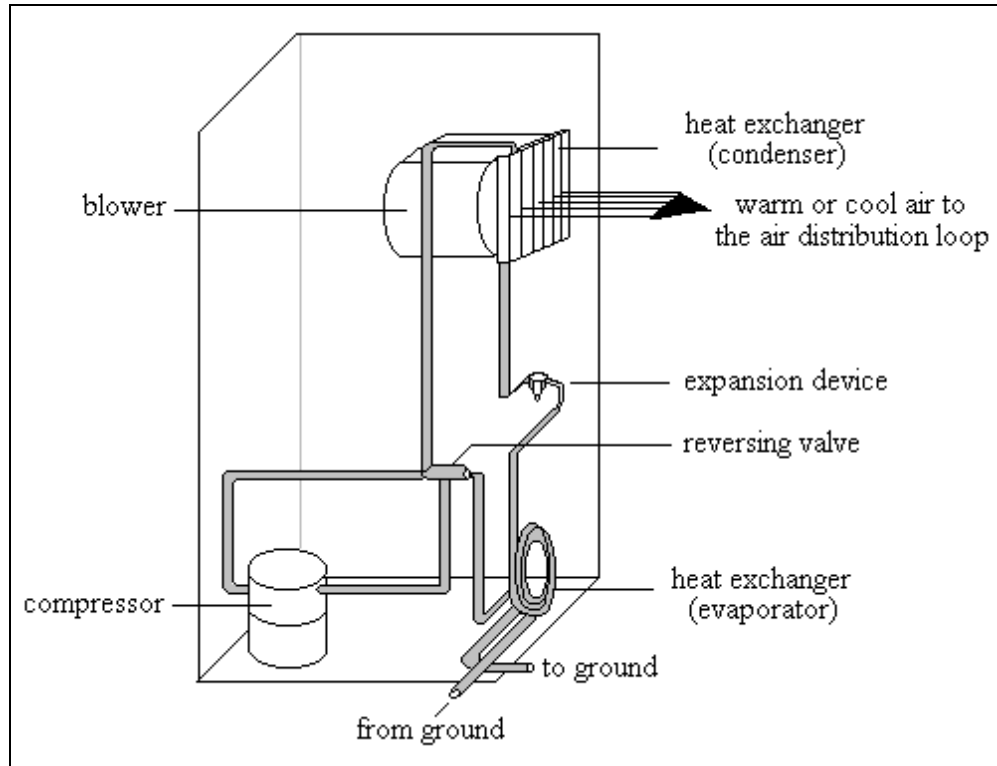

The main heat pump components are the refrigerant, evaporator, compressor, condenser and expansion valve. To heat or cool a building, a heat pump uses a liquid refrigerant such as R-22, which has a very low evaporation point: -40°F . When heating a home, for example, the cold liquid refrigerant absorbs heat and evaporates as it passes next to warmer antifreeze solution or groundwater in the evaporator (heat exchanger). The refrigerant gas travels through a compressor where it is squeezed and heated further to about 180°F . The refrigerant then moves to the condenser where heat is released to surrounding cooler air (forced air system) or to circulating water (hydronic system).

In forced air systems, a blower transports the warmed air around the building through a duct network. The venting is usually composed of insulated metal pipes, diffusers and grilles. The ducts carry the heated air, which usually has a temperature between $85\text{-}110^{\circ}\text{F}$. This is much lower than temperatures produced by fossil fuel furnaces, but higher than that of conventional air source heat pumps. Therefore, the volume of air that must be moved to supply the same amount of heat is much greater – the duct system and blower must be larger than those for conventional heating and cooling. A hydronic system uses a pump to circulate the heated or cooled water through a series of radiators in the building.

As the refrigerant loses heat to the air or water, it condenses back to a liquid under high pressure. It then passes through an expansion device where the pressure is lowered and the refrigerant cools further. Finally, the refrigerant returns to the evaporator to repeat the cycle.

To provide cooling to a home in the summer, the process would be reversed by changing the direction of the reversing valve on the refrigerant loop. The roles of the condenser and the evaporator are reversed during the cooling cycle. Heat from the home would be absorbed by the refrigerant (at the air distribution loop) and then transferred to the water or antifreeze at the ground loop, which in turn carries the heat to the subsurface.

An additional device known as a desuperheater can be used in either the heating or cooling mode to apply existing compressor heat to heat water. The desuperheater is attached directly after the compressor.

2.3. ENERGY USAGE

According to the EPA, GSHP systems can reduce energy usage by over 40 percent in comparison to air source heat pumps. Compared to electric resistance heating with standard air-conditioning equipment, GSHP systems can reduce energy usage by over 70 percent. Additional savings can be obtained with the use of other energy-efficient procedures and materials including insulation and thermally improved windows.

A domestic heat pump is typically a 3- or 4-ton capacity unit. One ton of cooling equals 12,000 BTUs per hour. A small business office or a church might require a 15- to 25-ton unit, whereas a high school might require a system greater than 200 tons.

2.4. SUBSURFACE VS. SURFACE TEMPERATURES

Although heat can be recovered from the air by using an air heat pump, the subsurface offers more favorable temperatures since they remain relatively constant. The temperature of Pennsylvania's groundwater, which generally reflects the subsurface temperature, ranges from approximately 48° F in the Northwest to 55° F in the Southeast. Temperatures are fairly constant from 5 to 50 feet below the surface; below 100 feet, temperatures rise about 1° C for every 100 feet. Subsurface temperatures fluctuate more widely near the surface. Soil temperatures can be determined by direct measurement, by design graphs of subsurface temperature variation, and by equations.

Surface water has been used with open heat pump systems; however, it tends to vary in temperature and may be less suitable because of suspended solids that could clog the intake. Plant growth also can be a problem. Closed-loops placed in ponds or lakes can take advantage of the cooler water temperature. However, such water bodies can reach fairly high temperatures in the summer. This could reduce the effectiveness of the cooling cycle. Of course, if a shallow pond or lake freezes solid in the winter, it would affect the system efficiency and possibly damage the loop.

2.5. TYPES OF SYSTEMS

There are two main types of GSHP systems: 1) closed-loop systems and 2) open systems. Variations of closed-loop systems are based on the configuration of the pipe, the type of antifreeze solution and the amount of heating and cooling required. Open systems vary according to the use and disposal of groundwater.

Closed-loop systems rely on the contained circulation of fluids through an underground loop of pipes. The loop acts as a subsurface heat exchanger, which transports the heat to or from the ground. The loop of pipe is installed either vertically in borings or horizontally in trenches. Traditional loop systems contain an antifreeze solution. Different types of antifreeze fluids have been used in the loops.

Another type of closed-loop system is the direct exchange (DX) heat pump system. In a DX system, the underground loop contains the refrigerant. This loop combines the refrigerant and underground loops.

Open systems (groundwater heat pumps) typically depend on the circulation of groundwater from a supply well to a discharge area. The source for heat (groundwater) is moved from the ground to the heat pump in the building; then the water is disposed of by surface or subsurface methods.

The selection of the type of system (closed-loop or open) will depend on many factors. They include availability of groundwater, soil type, energy requirements, size of lot and the experience of the local

contractor (see Chapter 6). For example, a rocky soil may prevent trenching. In that case, the contractor could use borings to install a vertical loop system. A small lot may allow only a vertical loop system. Some homeowners could take advantage of a pond or lake, or a well that has a sufficient supply of groundwater.

Commercial systems are typically larger GSHP systems that are used for such buildings as offices and schools. Commercial systems tend to have to deal with additional concerns such as distribution of energy and heat gain from different uses and locations of individual buildings or rooms.

2.6. ORGANIZATIONS INVOLVED WITH INSTALLATION

Various organizations are involved with the GSHP industry. They include utility companies, electric cooperatives, contractors, design engineer and hydrogeological consultants, manufacturers of equipment, universities and research organizations and government.

Utilities and electric cooperatives have become involved in the promotion and in some cases installation of GSHP systems. Rebates or credits are sometimes offered to encourage the use of energy efficient technologies.

Engineering and hydrogeological consultants design GSHP systems and conduct preliminary site investigation for commercial systems. The type and size of systems are determined based on the energy needs and the site conditions.

Contractors generally do most of the on-site installation work. They dig trenches, drill borings (some contractors may subcontract drilling work), run the piping, make the plumbing and electrical connections, and check, flush and start the system.

Equipment manufacturers furnish the heat pumps, pipes and associated equipment for use in the GSHP systems. Materials and equipment standards are maintained by groups like the American Society for Testing and Materials (ASTM) and the Air-Conditioning and Refrigeration Institute (ARI).

Universities, societies, and research organizations often provide innovative techniques and testing of procedures and equipment to determine the effectiveness of the system. For example, the International Ground Source Heat Pump Association (IGSHPA) recommends equipment and materials that have ASTM standards. Requiring certain products is a way of promoting quality assurance in the installation of a GSHP system. Research continues on all aspects of GSHP systems including antifreezes, grouts and materials. Changes and improvements in technology are likely to continue. Conferences and organizations are good ways to keep in step with the changes and progress with the industry.

Governments may provide standards and regulation of the industry and/or equipment. In addition, government agencies like DEP may become involved in the event of a system failure or problem that poses a threat to the environment or for system permitting.

The Geothermal Heat Pump Consortium (Geoexchange) has been established to create “a sustainable market” for GSHPs that will in the process reduce greenhouse gas emissions and improve the nation’s energy efficiency. The consortium includes government and industry representatives.

Additional sources for more information are listed in Section 6.2. Selected publications by different organizations are noted.

3. CLOSED-LOOP GSHP SYSTEMS

The closed-loop GSHP systems rely on the temperature of the soil or rock, groundwater or surface water to provide heat or to accept it. The principles of operation are the same as those described in Section 2.2. System variations generally involve the loop design and the antifreeze solution. A wide variety of configurations have been used on closed-loop GSHP systems; however, they generally can be classified as vertical or horizontal systems.

3.1. BASIC OPERATION

The typical closed-loop GSHP system consists of three types of loops: a subsurface loop, a refrigerant loop and the cooling/heating distribution loop. The subsurface loop typically consists of polyethylene pipe, which is placed horizontally in a trench or vertically in a boring. This thin-walled pipe acts as a heat exchanger, which transfers heat from or to the ground. Antifreeze fluids inside the pipe are circulated to the heat exchanger of an indoor heat pump where it releases heat to the refrigerant. The refrigerant loop typically consists of copper pipes that contain a refrigerant. The last loop of the system consists of the forced air or hydronic system to distribute the heated or cooled air throughout the building.

3.2. DIRECT EXCHANGE (DX) SYSTEMS

DX systems operate the same as other closed-loop systems except that the underground loop and the refrigerant loop are functionally combined. The direct exchange loop operates with copper pipes (typically ¼- to ¾-inch tubing is used) that are placed underground. The refrigerant is circulated directly through the subsurface. Typically, 500 square feet per ton is required for the ground loop.

A DX system requires several times the amount of refrigerant normally used, and any holes in the copper tubing would cause a loss of the refrigerant. Typically 10 to 20 pounds of refrigerant are used for domestic systems. The copper pipes can be susceptible to corrosion in acidic soils though this is typically not a problem. Care should be taken to avoid soil conditions that would be aggressive to copper pipes. Wet soil areas with high electrical conductivities should be assessed for potential stability of the ground loop of a horizontal DX system.

Heat from the pipes can bake fine-grained soils that surround a horizontal underground loop. This can reduce the efficiency of heat transfer and thus the performance of the system. Moist sandy soils or sand bed installations are more suitable for the operation of DX systems. Vertical boreholes should be backfilled with cement grout instead of bentonite-based grouts.

3.3. THERMAL BEHAVIOR OF SOILS AND ROCKS

The rate of heat transfer between the loop and the surrounding soil or rock is determined by the thermal conductivity. Knowing the approximate thermal conductivity of the geologic unit is important when designing the closed-loop system. The conductivity value is used in equations to determine pipe lengths that will achieve an adequate quantity of heat transfer.

Rock and soil types can be determined by visual inspection and/or laboratory work or by reference to geological publications. Various geological maps and documents covering most of the state can be obtained from the State Book Store (see Section 6.2).

The thermal behavior of soils is primarily controlled by soil composition, soil moisture, vegetation and the local climate. Soils can be divided into two main types: coarse-grained soils and fine-grained soils. Coarse-grained soils such as sands can be a good conductor if there is ample moisture. Dry coarse-grained soil

may not conduct as well. The identification of soil types can be done in the field or by using soil maps. Trained persons can make accurate judgments on soil types.

A fine-grained soil is a much better thermal conductor than a dry coarse-grained soil. However, clayey soils are typically more difficult to handle when digging trenches for horizontal loop systems. If the soil clumps during excavation of a trench, other soil may have to be placed around the pipe. In addition, dry clayey soils can heat up and reduce the effectiveness of a closed-loop system. The best types of soils tend to be sandy loams, sandy clay loams, loams and perhaps sandy clays. Moist soils also will conduct heat much better than dry soils. A method to trickle water in the pipe area can increase the efficiency of heat transfer.

The thermal behavior of rock is controlled by its mineralogy, porosity and fabric (texture or structure). Because these factors may be highly variable in a geologic formation, the thermal conductivity for a given rock type usually is reported as a range of values. Determination of rock types in the field will generally require a geologist. Because of the wide range of rock types (even within a formation), the system designer should exercise caution when assigning conductivity values to rocks based on maps.

Because of the potential wide range of rock conductivity, designers of large volume systems should consider using *in situ* thermal conductivity tests for site-specific values.

3.4. CIRCULATING FLUIDS

Closed-loop systems require a heat exchanging circulating fluid, often referred to as antifreeze. A good antifreeze solution will have the following favorable qualities:

- low cost
- low toxicity
- low viscosity
- low volatility
- low corrosivity
- low flammability
- low freezing temperature
- high thermal conductivity
- long service life

The amount of fluid contained within the pipe is dependent on the length and diameter of the pipe. For example, a ¾-inch inner diameter pipe that stretches for 1000 feet will contain 25-30 gallons of fluid underground.

The antifreeze solution types vary as to their risk to the environment. The common types of solutions include the following:

- water
- potassium acetate
- sodium chloride water
- calcium chloride water
- ethanol and water
- methanol and water
- ethylene glycol and water
- propylene glycol and water

Advantages and disadvantages of the various circulating fluids are shown in Table 1. Nontoxic, biodegradable circulating fluids such as food grade propylene glycol are recommended for use in GSHP

systems. Corrosion inhibitors can be added if necessary; however the antifreeze must meet the International Ground Source Heat Pump Association criteria for toxicity.

3.5. TYPE AND AMOUNT OF PIPE

Polyethylene is the only type of pipe that is recommended. This material is flexible, very resistant to weathering and good heat transfer medium. Some manufacturers guarantee the life of the pipe to be at least 50 years. Also, the joints can be fused together by heat, which creates a strong connection. Pipe diameters of 3/4-inch or one inch are most commonly used. Larger sized pipe tends to be more difficult to handle and more expensive.

The amount of subsurface pipe needed depends on several factors including energy demand, structure and size of the building, climate, location of the loop and thermal conductivity of the subsurface. Many contractors offer computer analysis that determines the necessary length of pipe to meet the energy requirements of the building.

3.6. LOOP CONFIGURATIONS

Configuration of the subsurface loops can be almost any shape (Figure 2). Typical patterns include long trenches, parallel shorter trenches, radiating, coiled and vertical borings. The loop can circle the building or be placed in a nearby water body, such as a pond.

The pipe can be placed in either series or in parallel if more than one trench or boring is used. In series form, only one flow path is made; in parallel form more than one flow path is maintained using headers that branch off from the main supply or return pipe. Headers can be placed in a common area to allow individual flow paths to be checked for leaks without excavating a large area. Series setups usually require less fused joints, but larger diameter pipes than parallel configurations.

TABLE 1: CIRCULATING FLUIDS

ANTIFREEZE FLUID	ADVANTAGES	DISADVANTAGES
Water (W)	Low viscosity Inexpensive High thermal conductivity Non-toxic	Corrosive Impurities Expands as it freezes High freezing point
Calcium Magnesium Acetate	Non-toxic Not flammable	Can easily seep Can be corrosive
Sodium chloride and water (SC)	Low viscosity/toxicity Inexpensive Low volatility Not flammable	Very corrosive High freezing point Requires extra care
Calcium chloride and water (CC)	Same as SC Lower freezing point than SC	Requires extra care Very corrosive More expensive than SC
Urea	Non-toxic	Can easily seep; corrosive
Methanol* and water (MA)	Inexpensive Low corrosivity Good conductor	Volatile Flammable Toxic
Ethanol* and water (EA)	Less volatile than MA Inexpensive	Flammable; toxic less viscous than MA Less conductive than MA
Ethylene glycol and water (EG)	Non-corrosive Low volatility Low flammability	Finite service life More expensive than EA Toxic High viscosity at low temperatures
Propylene glycol and water (PG)	Non-corrosive Low volatility Low flammability Lower toxicity than EG	More viscous than EG More expensive than EG

*Flammable as pure fluid. Fire risks are very low after mixing with water.

3.6.1 Horizontal Loops

A horizontal loop can be placed in narrow, 5-10 feet deep trenches that are hundreds of feet long. The ground loop can be installed in parallel trenches that do not require such lengths. Loops of overlapping coils require even shorter trenches. An installer can place 500 feet of overlapped coils in an 80 foot trench, or two loops totaling 1000 feet of pipe in the same trench. Coils can be laid flat at the bottom of a trench or placed vertically in a narrow trench. The depth of the trench must be below the frost line to avoid any problems in the winter. A depth of five feet is usually sufficient in Pennsylvania. For domestic systems that use a pond, the minimum pond size should be 6-8 feet deep and 1/2 acre in area (approximately 150 feet by 150 feet).

FIGURE 2. SERIES LOOP CONFIGURATIONS
(not to scale)

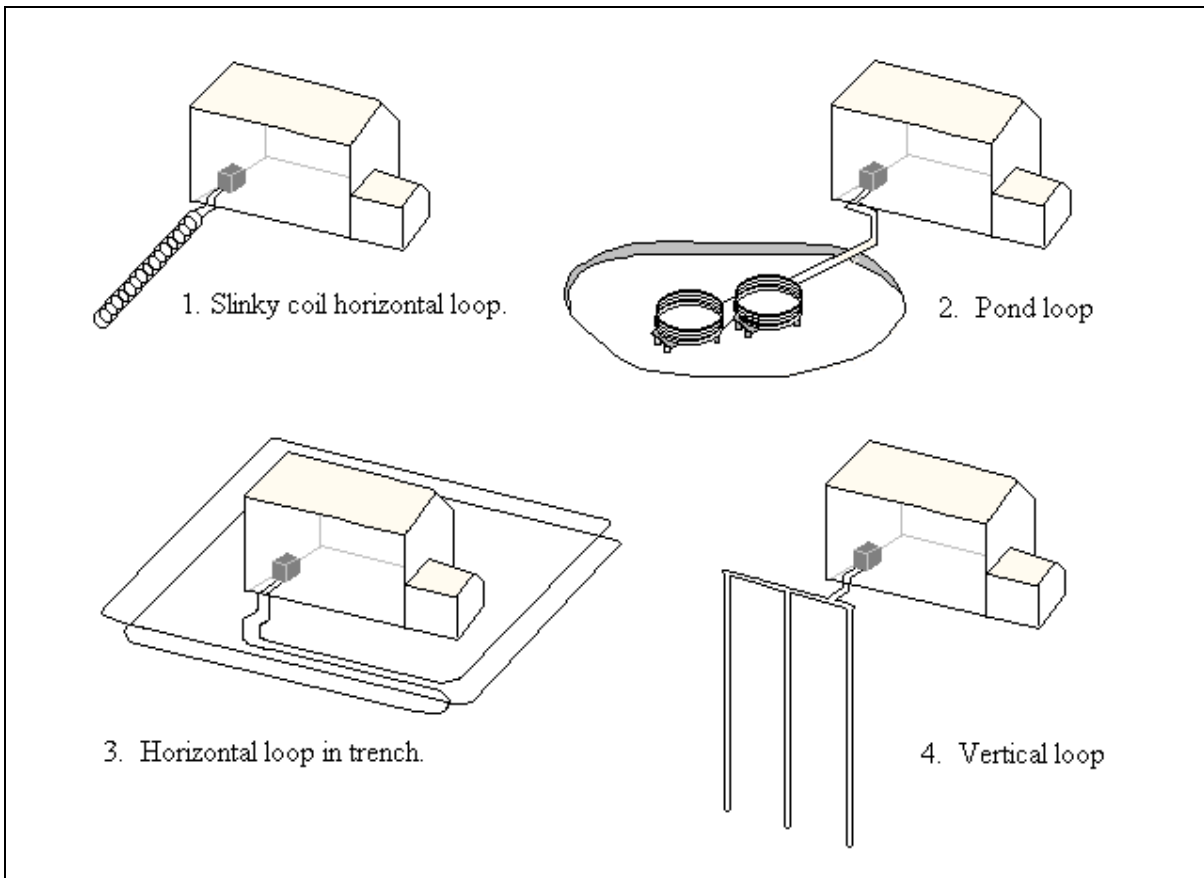

3.6.2 Vertical Loops

Vertical loops are most often installed in drilled borings (Figure 2). Pipes that circulate fluids are typically installed to depths up to 150 feet. Multiple connected borings can be used for homes or businesses. Typically 125-200 feet of borehole is required per ton of heating/cooling unit. A three-ton unit will thus require 375-600 feet of borehole. The horizontal spacing between borings should be between 20 and 25 feet. The spacing must be able to handle the short and long term effects of the heating and cooling cycles. Thermally enhanced grouts can reduce the footage of borehole required.

3.7. FLUSHING OF LOOPS

Flushing procedures are important checks to assure that the system will be in good operating order. These procedures will help to prevent system breakdown and/or possible loss of antifreeze fluids to the subsurface.

3.7.1. Debris Flushing

After the pipe has been connected and installed in the trench, boring or pond, the installer should flush the system with water to remove debris such as plastic cuttings or dirt introduced during installation. The valve to the heat pump loop is closed during this procedure.

3.7.2. Air Purging

Following the debris flushing, air purging is done to eliminate entrapped air to avoid corrosion problems. Typically a contractor cycles water through the system and into a container until the air bubbles disappear. A flow of at least two feet per second must be maintained to eliminate pockets of air that may develop in a system. In parallel pipe systems, the inherent velocity drop must be overcome to reach the two feet per second requirement.

3.7.3. Pressure Testing

After the debris flushing and air purging, and before the trenches or borings are grouted or backfilled, the loop should be pressure checked for leaks. Leaks in the piping can occur because of shipping or installation damage or from improper joint fusion procedures.

The pressure check is performed by circulating water through the subsurface loop. Standard municipal water pressure can generally be used during this test. Air pressure should not be used because pipes can break and flail.

Failures in the piping will almost always occur at a joint that has been improperly sealed. Another common mistake occurs when the connecting hole is not drilled out after a header is installed. Obstructions sometimes occur where the pipe has been kinked (often at corners where no U-bend or pipe corners have been used). An obstruction such as a kink in the hose will be detected during a pressure check. Since the excavation has not been backfilled, problems with the system are then easily detected and corrected.

3.7.4. Final Charging

After pressure testing, the system is ready to be charged with antifreeze. This procedure involves replacing the water that was used to pressure test the pipes with the antifreeze solution. A flush cart is typically used to flush and charge the loop. This device is basically a water reservoir with attached hoses and service valves.

3.8. BACKFILLING AND GROUTING

After a system has been installed, tested, and charged, the loop is ready to be backfilled or grouted. Backfilling and grouting are important steps in the GSHP installation process. Poor procedures can affect heat transfer from the pipes and can result in the spread of contamination in the event of a leak.

3.8.1. Backfilling

When backfilling a horizontal loop, the installer should be careful that no rocks are in contact with the pipe. The contractor may need to place a bed of sand or limestone “crackerdust” at the bottom of the trench to insulate the pipe from rocky soil while providing a conductive medium. Sand also may be required to surround the entire pipe before the native soil is returned to the trench. Compaction machinery may be necessary to develop good contact between the soil and the pipe.

A new option is to use flowable backfill that surrounds the pipe in the trench. Flowable backfill has the advantage of complete contact of a highly conductive material with the pipe. The backfill material typically consists of water, sand, cement and fly ash. The use of fly ash may be categorized as beneficial use for this waste. However, whether the fly ash can be used depends on its chemical composition, location and volume to be placed in the ground. The contractor should contact the appropriate DEP regional office.

3.8.2. Grouting

Grouting refers to the placement of grout – a permanent water tight barrier made of low permeability cement, bentonite or other mixture – into the boring. In vertical loops, the grout is placed down the hole where the pipe has been installed. All vertical loops should be grouted for several reasons. A proper grout seal will provide a barrier to groundwater migration around the boring. Therefore, flow between two aquifers is prevented. A proper seal can also prevent surface contamination from moving down the side of the hole to the aquifer. Moreover, where groundwater is not present in the boring, the grout becomes a better medium for heat transfer since air is a poor heat transfer medium. Thermally enhanced grouts have been developed that improve the thermal conductivity of the grouted borehole. Silica is added to the cement or bentonite grout.

A proper grout for closed-loop systems will have the following properties:

- high thermal conductivity to allow heat transfer
- low viscosity to allow the grout to wrap around the pipe
- low shrinkage volume to ensure that the grout will not pull away from the pipe
- low permeability to prevent the migration of antifreeze solution in the event of a line breakage

A grout with these properties will not only protect the subsurface from contamination, but will also provide a medium for heat transfer.

If a confining layer is penetrated during drilling, then the grout should also seal off this layer, and adequately isolate the water bearing zone. Grouting is the best method for confining the water to its native aquifer. In addition, if surface casing is used to keep the borehole open, then the entire annular spacing along the outside of the casing should be grouted.

3.8.2.1. Grout Materials

Grout materials, which do not include drilling muds, fluids or gels, can be divided into two main types: cement-based or bentonite-based grout. Advantages and disadvantages are presented in Table 2.

Cement-based grouts with 5-10 percent bentonite are commonly used in Pennsylvania. However, cement-based grouts are prone to shrinkage and heat of hydration and they may not adhere to the plastic pipe. For these reasons, the bentonite-based grouts are recommended over the cement-based grouts. Silica can be added in specific proportions to both grout types to increase the thermal conductivity.

Types of effective bentonite sealing materials include high solids (powdered or granular) bentonite. High solids bentonite can be pumped before its viscosity is lowered. These grouts will usually require higher pumping pressures than cement grouts. In several states, pure bentonite grout with approximately 20 percent solids content has become the standard for sealing vertical loops in borings. This type of grout is composed of at least 20 percent solids content by weight of bentonite when mixed with water. To determine the percentage, the weight of bentonite is divided by the weight of the water plus the weight of the bentonite. For example, if 75 lbs. of powdered bentonite and 250 lbs. of granular bentonite were mixed in 150 gallons of water (at 8.34 lbs. per gallon), the percentage of high-solids bentonite is approximately 20 percent $(325 \div (1251+325) \times 100 \text{ percent})$.

Pelletized and coarse-grade (solid) bentonite can also form good seals, but proper placement may be difficult (See next section).

TABLE 2. GROUT TYPE ADVANTAGES AND DISADVANTAGES⁰

CEMENT-BASED GROUT	
<u>ADVANTAGES</u>	<u>DISADVANTAGES</u>
Readily available Forms suitable permeability Easily mixed and pumped	Heat of hydration may affect plastic pipe May not stick to pipes Requires time for curing High density Shrinkage likely
BENTONITE-BASED GROUT	
<u>ADVANTAGES</u>	<u>DISADVANTAGES</u>
No heat of hydration Faster setting time Casing can be pulled after grouting Permeability is suitable Low density	Difficult pumping, mixing and cleanup Low soil moisture may cause shrinking and cracking Salt water and organic acids may affect seal with high solids content

3.8.2.2. Grouting Procedures

Grouting is a highly variable operation in which many things can go wrong. Many factors can affect the behavior of the grout including components, ratios, temperature, chemical compositions of the water and bentonite, pH, etc. For example, inappropriate mixing ratios can lead to ineffective seals. Also, improper emplacement techniques may lead to gaps in the seal. For each type of bentonite, the manufacturer's instructions must be followed. In

addition, it is critical for the contractor to be experienced and prepared for the grouting operation. Different bentonite types and mixing ratios can produce much different viscosities and setup times.

Closed-loop borings should be grouted in one continuous operation from the bottom to the top using a tremie or conductor pipe. For high solids bentonite grout, the type of pumps used includes positive displacement pumps such as piston, gear and moyno (progressive cavity) pumps. A paddle mixer is typically used to mix the grout.

Pelletized and coarse-grade bentonite also can form good seals, but problems exist in the placement of this type of bentonite. Because pelletized and coarse-grade bentonite are poured down the borehole, extreme care must be taken so that the particles do not bridge above the bottom of the hole. At least 2 inches of space should exist around the heat exchanger pipe if this method is used. When groundwater is not in the borehole, water must be added often to hydrate the bentonite. Because of the potential for gaps in the seal, this method is generally not suitable for the deep borings that are required for the heat exchanger pipes. However, this method is excellent for sealing abandoned borings (see Section 1.4).

Emplacement of dry bentonite granules by air injection into a saturated borehole can be accomplished. Quartz sand can be added to increase the viscosity and conductivity of the grout. Air injection of bentonite can produce high percentage solids content of bentonite.

3.9. POTENTIAL WATER QUALITY PROBLEMS

In general, the risk of groundwater contamination from closed-loop GSHP systems is very low. However, with an antifreeze fluid that is circulated through the pipes, the potential exists for a leak or rupture to occur that allows the antifreeze to escape. If the fluid is a polluting substance such as a methanol or ethylene glycol, the system owner can be liable for cleanup of the soil and/or aquifer. For this reason, the biodegradable mixtures such as food grade propylene glycol are recommended.

Thermal pollution by most closed-loop GSHP systems is likely to be negligible. Although some larger systems could locally affect subsurface temperatures, use throughout the year will tend to offset the effects of heating and cooling (see Chapter 5).

Pump motors on the heat pumps typically operate on vegetable or mineral oil; most heat pumps have an automatic shutoff device that activates if the system loses pressure. Although there also is a slight chance that pump motors and the actual heat pump system could rupture, the result will most likely be of little consequence to the environment. The refrigerant is also non-toxic. However, all systems should be equipped with pressure shutdown switches.

3.10. ENVIRONMENTAL CONSIDERATIONS AND RECOMMENDATIONS

The International Ground Source Heat Pump Association (IGSHPA) has established standards for GSHP systems. It is recommended that IGSHPA standards be followed. Information regarding these standards can be obtained from IGSHPA (see Section 6.2).

Closed-loop pipes should be made of polyethylene and all joints should be sealed by the heat fusion or other IGSHPA certified process. The system should be flushed and pressure checked before the borings are sealed or the trenches are filled. Even though the pipes may last decades without problems, in time the pipes may develop leaks. For this reason, it is strongly recommended that non-toxic fluids be used. Any corrosion inhibitors should be used with caution and meet IGSHPA standards. It is also recommended that

the subsurface loops be isolated at least 100 feet from any drinking water wells and 25 feet from any septic systems.

General recommendations are presented in Chapter 6. The following recommendations are specific to closed-loop GSHP systems.

3.10.1. Horizontal Loops

The trenches for horizontal loops should be at least 25 feet away from any septic systems. Heat from the pipes can increase biological growth in the septic tanks, which could lead to costly septic system repairs.

3.10.2. Vertical Loops

The borings for vertical loops should be at least 25 feet away from any septic systems. Vertical loop borings should be grouted with a low permeability material to prevent the following from occurring:

- contamination of groundwater from surface sources
- intermixing of aquifers by flow via the borehole
- disruption of aquifer hydraulics

The driller can prevent these situations by maintaining the conditions of the aquifer that existed before the boring was installed. An impermeable barrier placed around the piping can prevent water from moving vertically in the boring. Ungrouted borings would be considered wells and should be placed 100 feet from any septic system.

4. OPEN GROUND SOURCE HEAT PUMP SYSTEMS

Open GSHP systems, also known as groundwater heat pump (GWHP) systems, typically depend upon groundwater to supply or accept heat. Open systems do not confine fluid to a loop of pipes; they use a pumping well to move water through the heat pump. Although surface water could possibly be used, most open systems rely on groundwater. The water is disposed of by a surface or subsurface method. The water supply well must yield enough water to transport the required amount of heat.

4.1. GROUNDWATER AVAILABILITY

Groundwater, an invaluable natural resource of Pennsylvania, can be found in virtually every area of the state. This resource supplies approximately one-half of the population with their domestic water needs through municipal supplies, private and public water companies and private wells. In some areas, groundwater is the only available or practical source of drinking water.

The emergence of the heat pump allowed groundwater to be used as an economical source of heating or cooling. In the winter, groundwater is usually much warmer than the air temperature. A heat pump can take heat from the circulated water and transfer it to a building. In the summer, the heat in a building can be transferred to the cooler groundwater.

Fortunately, Pennsylvania is a water-rich state, receiving an average annual precipitation of 42 inches. Approximately one-third of the precipitation infiltrates to groundwater, maintaining the storage of trillions of gallons of underground water.

Groundwater also provides base flow to Pennsylvania's 83,000 miles of surface waters. In times of drought, most of the surface water flow is produced by groundwater. Although droughts and overuse can threaten groundwater supplies (in certain regions at certain times), generally there is an adequate supply of groundwater. Groundwater typically can be found within 100 feet of the surface, which makes it accessible. However, local interference from nearby pumping wells can occur, as discussed in Section 4.6.6.

In areas of non-potable groundwater, GWHPs could provide a beneficial use if the water quality is satisfactory for the system. In many areas of the state, large volumes of water lie beneath mining regions.

4.2. BASIC OPERATION

During the winter heating cycle, the GWHP system operates by extracting heat from the groundwater and transferring it to the building. During the summer cooling cycle, heat is transferred away from the building by the groundwater. A typical GWHP system is shown in Figure 3.

FIGURE 3. GROUNDWATER HEAT PUMP SYSTEM

(not to scale)

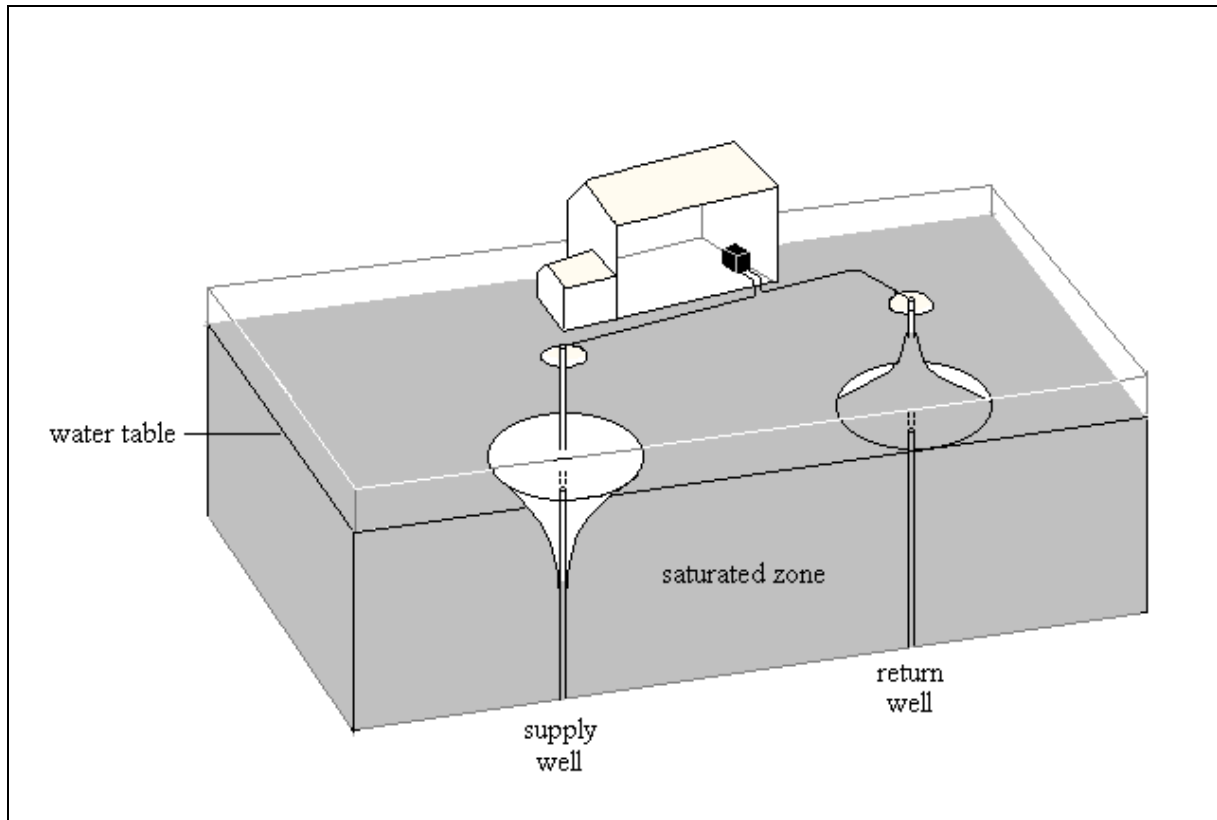

Groundwater is piped from the ground to the tubes of a heat exchanger (evaporator). The refrigerant, contained in tubing, surrounds the water pipes. The exchange of heat then occurs by the same process as described in Section 2.2. Meanwhile, the groundwater exits the heat exchanger and proceeds to the disposal area. The selection of the size of the groundwater pump is an important decision. The pump must be large enough to overcome the friction in the piping and to supply enough water for the heat pump and other uses. On the other hand, the pump must be small enough to be efficient in energy usage and water supply.

Residential groundwater heat pumps will typically use 3-12 gallons per minute (gpm) or 4,320 to 17,280 gallons per day (gpd) during operation, depending on the heat pump efficiency and the amount of cooling or heating necessary. A rule of thumb is that for every ton of heating pump, 2.5 to 3 gpm of flow will be necessary. A rural well that will supply all the water for the home may require a yield of 20-30 gpm to meet the peak flow requirements.

4.3. TYPES OF SYSTEMS

Variations of GWHP systems are generally based on the arrangement of wells and the disposal method. Typically homeowners and commercial systems use a two-well system – one for supply and one for discharge. A supply well can also be used for discharge; this is known as a standing well system. Several other disposal methods are possible (see Section 4.4). GWHP systems also may need different sized wells based on the amount of groundwater required.

4.4. DISPOSAL OF WATER

The circulated groundwater, with only its temperature changed, requires disposal. Disposal can be accomplished by both surface and subsurface methods. During severe cold outbreaks, the pumps may require constant use. For example, a domestic GWHP system that requires heavy use may produce over 15,000 gallons of water per day. Commercial systems would require much more groundwater.

The largest volumes of water will be produced during the coldest part of winter. The disposal method must be compatible with the volume of water that will be discharged and must be able to handle the extreme weather conditions. During the spring and fall, the volume of water required will be reduced.

Because of the expense involved in the construction of a second (return) well, the installer may prefer surface or near surface disposal methods. However, many situations will not allow these methods (see following section).

4.4.1. Surface Disposal

Surface disposal is generally the easiest method for disposing of the used groundwater. The disposal locations can include on-site or off-site ponds, streams and other bodies of water. Each disposal method poses some environmental and operational disadvantages.

The used water may be diverted to a surface water body, such as a lake or stream; however, this action may require a NPDES permit for the discharge. The system operator should contact the appropriate DEP regional office for more information. The method of conveyance must be secure to avoid problems with erosion and sedimentation, which can impact the stream or lake. Additional problems may occur in the winter because of freezing conditions. Long-term impacts to groundwater levels are possible if discharge exceeds recharge.

Water may be channeled to a private, on-site collection basin where it infiltrates into the ground. This type of disposal is generally successful only where the basin bottom is composed of highly permeable sands and gravels. Otherwise, infiltration tends to be too slow; periodic maintenance must be done to clean the basin. Along with silting, microbial and bacterial plugging are the chief causes of the permeability reduction. Basins also require large areas of property. Disposal to a private basin would not require a permit.

Another possibility is to discharge water into a storm sewer with permission from the municipality. This option is generally precluded by limited access to the sewer. Also, this method does not recharge the local aquifer.

Disposal to sanitary sewers is typically prohibited because of local ordinances. Such discharges can lower a sewage treatment plant's efficiency, thereby raising operating costs.

4.4.2. Subsurface Disposal

Most subsurface methods return water to the aquifer by a vertical injection well. This method conserves groundwater and tends to limit environmental problems. When water is returned to the same aquifer, groundwater quality and quantity are generally maintained.

Another method of subsurface disposal uses horizontal drains or a subsurface drain field. The drains must be able to accept the volume of flow from the GWHP. It also must be deep enough to avoid freezing problems in the winter.

Because the temperature of the water has been changed, some chemical changes can occur when the groundwater is injected. For example, changes in pressure and CO₂ could lead to the precipitation of minerals and the eventual clogging of return wells (see Section 4.6.5). Clogging also can occur from the development of iron oxides caused by aeration of the water. Bacteria also can cause iron to form which can restrict flow into the aquifer. Suspended sediment can also block openings in the well.

4.4.2.1. Standing Wells

A well used for both supply and discharge for a GSHP system is known as a standing well system. For this technique, a pipe with the bottom portion screened is placed down the well. Groundwater is pulled through the screen using a submersible pump, located near the bottom of the well. After the water circulates past the heat pump, it is then returned to the well using a drop pipe at the top of the well. The water cascades down the outside of the pipe and cools or warms, depending on how the water had been used.

The thermal capacity of the well is approximately 100 feet/ton; a 4-ton system would require a 400-foot well. This method conserves water but is generally limited to domestic systems. Although the existing well can be used for the return well, in time unfavorable hydraulic properties can cause the well to respond improperly. In many cases a second appropriately designed and constructed well will be necessary.

4.4.2.2. Discharge Acceptance by Wells

The return well must be able to handle the volume of water that passes through the heat pump. Aquifer characteristics such as the transmissivity of the area surrounding the well should be considered. Hydrogeological characteristics can be estimated based on the geology of the well area.

The installer should consider other factors including: 1) distance from existing wells, 2) volume of discharge water, 3) length of the well available for injection of the water, 4) design of the well screen (if used), 5) local water quality and 6) local and state well construction codes.

The return well must be adequately isolated to allow the discharge water to reach the ambient temperature of the aquifer before being withdrawn again. The wells typically should be isolated at distances greater than 100 feet (horizontal distances). Larger capacity wells or wells in thin or poorly transmissive aquifers should have greater isolation distances.

The construction of the return well is critical to the effectiveness of this type of water disposal. A well that is not constructed properly can at some point cause the entire system to fail. Problems often consist of well clogging or slowing because of either poor construction or the development of mineral precipitate that clogs the well.

Several actions can help to prevent precipitation of minerals, although results cannot be guaranteed. The well must be of sufficient diameter and depth to accept the maximum discharge from a GWHP system. The screened or open rock portion should be greater than that of the supply well. A return well constructed in rock typically requires twice the capacity as the supply well. An extended pumping test (12-24 hours) is recommended to help determine hydraulic characteristics of the return well. The use of a backvalve can help to prevent pressure differences that could result in precipitation of minerals.

Also, the well should be properly developed to remove fines and stabilize the borehole. Mechanical surging and some types of chemical treatment can promote a stable well, or successfully treat a clogged well.

How much water can a return well accept? This is an important question that can impact the success of the open GSHP system with an injection well. The rate of discharge acceptance can be estimated based on values determined from a pumping test of the well. A pumping test is accomplished by pumping the water well at a constant rate for at least an hour. Specific capacity is the observed rate of yield (in gallons per minute) divided by the drawdown that results during the pumping test. For example, if a well pumps at 10 gpm and the water level drops 5 feet, the specific capacity is two gpm/ft of drawdown. How much water the well will accept is related to its specific capacity.

To push water back into the aquifer, the pressure on the column of water must be greater than the pressure resisting flow back into the aquifer. Therefore, the discharge water will "mound" inside the well until enough pressure is built up to force the water into the aquifer.

The term "head" is used to denote the height of the water in the well. The "injection head" is how far the water rises before water will be moved into the aquifer. Injection head depends on many factors including the construction of the well, the discharge rate of the return water, the aquifer's ability to transmit water and how much water is held in the borehole area.

The theoretical value of the injection head can be calculated by dividing the discharge rate by the specific capacity. For example, if 10 gpm is returned to the well that has a specific capacity of two, then the injection head will be five feet. If a positive number results when the injection head is subtracted from the depth to water (static water level), then the water will not overflow at the surface. A specific capacity value of less than 1 gpm/ft may cause overflow at a well that is only 20-25 feet deep. A water injection test can be performed to see how the well reacts.

The installer should consider that any decrease in the aquifer transmissivity will result in an increase in injection head. Clogging of the open spaces in a well will eventually bring the water to the surface.

4.5. LEGAL REQUIREMENTS OF DRILLERS

Water well drillers must be licensed under the Water Well Drillers License Act. This program is administered by the Department of Conservation and Natural Resources, Bureau of Topographic and Geologic Survey, P.O. Box 8453, Harrisburg, PA 17105-8453 (Telephone: 717-787-5828).

This law also requires drillers to complete a well description report on ("Water Well Completion Report") a form provided by the Bureau. The form requests information on the geology, construction details and use of the well. The driller must provide the well owner and the state a copy of the report.

4.6. POTENTIAL SYSTEM AND WATER QUALITY PROBLEMS

The use of open GSHP systems can be an environmentally safe operation. However, potential water quality and quantity problems include:

- change in groundwater temperature
- leakage of chemical additives to the water outflow
- leakage of machinery pollutants
- abuse of injection wells by injecting sewage wastes
- change in the chemical balance of the aquifer
- overpumping and/or well interference
- land subsidence

4.6.1. Change in Temperature

The returning groundwater will either be warmer or cooler. For GWHP systems, the temperature is usually changed less than 10° F. Whether or not the discharge will have an impact on the water depends on various factors such as the volume discharged, the temperature and flow of the receiving water and other factors. If the cooling and heating water are returned to the same aquifer throughout the seasons, the temperature contrasts will tend to be neutralized. For surface disposal, heat is categorized as a pollutant under NPDES.

For subsurface disposal, large GWHP systems could possibly introduce a thermal plume that could affect another well. The potential for this should be assessed during the design of a large system (see Chapter 5).

4.6.2. Chemical Additives

Chemical additives for any purpose may not be supplied to the return flow of groundwater. The use of chemical additives changes the classification of the injection well. Before adding anything to the water, the system owner should contact the DEP regional office.

4.6.3. Machinery Pollutants

Machinery oils and refrigerants are generally benign sources of pollutants in heat pump systems. In household systems, the volumes of these substances are limited. Also, since the heat pumps are located inside the building, the risk of any type of contaminant reaching the subsurface is minimal. The amount of refrigerant and oils in commercial systems may pose some risk if the substances migrate to the subsurface. Most systems are equipped with automatic shutoff devices activated by pressure drops.

4.6.4. Sewage Disposal

GWHP systems should not be connected in any way to sewage disposal systems.

4.6.5. Chemical Imbalances

As groundwater flows through the GWHP system, the water may be slightly changed in quality including temperature pressure or dissolved oxygen. Such changes can cause the precipitation of insoluble materials such as iron oxides, calcium carbonate and silica. This may be the biggest problem with the use of open systems. Scaling, the deposition of a mineral precipitate, can occur in the pipes, valves or heat exchangers and thus reduce the efficiency of the system.

Serious scaling problems are rare. Scaling is most likely to occur during the air-conditioning mode when the heat exchanger gives off heat to the groundwater.

Precipitation of minerals can also result in the clogging of the return well and a shutdown of the GWHP system. Return wells are more likely to require maintenance than supply wells. Evidence that precipitation of minerals is occurring includes: 1) a marked decline in the recharge rate, 2) an increase in the amount of pressure needed to maintain the recharge rate and 3) rising water levels around the injection well. Well failure can occur so rapidly that the first symptom may be water flowing out of the return well. Proper design, development and maintenance can prevent injection well failure (see Section 4.4.2.2).

Water quality tests and consultation with system designer and equipment suppliers can avoid these types of problems. Also, improvements such as expandable cupro-nickel alloy pipes have reduced problems such as scaling. Filters can also help to alleviate the deterioration of valves by removing fine particles in the water.

4.6.6. Overpumping and Well Interference

Uncontrolled groundwater development of an area can lead to problems such as aquifer drawdown and well interference. Aquifer drawdown occurs when withdrawal exceeds recharge. Well interference can take place in areas where yields are low, use of groundwater is high or where supply wells are close to each other. The results are lower water levels in wells and smaller yields. In some cases, water levels may drop below pump intake levels resulting in "dry wells."

The surface disposal of groundwater could unnecessarily compound a situation where groundwater is in short supply. Groundwater should be conserved by returning it to the aquifer.

Whether or not similarly constructed wells will interfere with each other depends mainly on three factors: 1) the transmissivity of the local aquifer, 2) the pumping rates of the wells and 3) the distance between the wells.

An aquifer with a good transmissivity will generally provide enough water for each user. Carbonate, sand and gravel and highly fractured rocks will typically yield adequate quantities of water. Wells constructed in igneous and metamorphic rocks and shales and sparsely fractured rocks may yield small quantities of water. References for determining the geology of a region are listed in Section 6.2.

The demand for groundwater will vary with the size and design of the heat pump system. Overpumping can expand the cone of depression until it interferes with the area of withdrawal of another well. A high volume commercial well could affect nearby wells even in regions with highly transmissive aquifers.

Wells placed too closely to each other may also result in interference. A well should be placed at least 100 feet from an existing well. However, this does not guarantee that there will be no interference. In geologic formations with poor transmissivity, the cone of depression that develops will be deeper with steeper sides than in areas of high transmissivity. The cone of depression will continue to expand until hydrogeologic equilibrium is reached – when the flow into the aquifer equals the flow out. This process may take weeks or years.

4.6.7. Land Subsidence

Natural subsidence is generally restricted to regions of carbonate rocks. Carbonate rocks (limestone and dolomite) are susceptible to dissolution, which may be followed by subsidence of the land above. The factors involved in subsidence include the composition of the carbonate rock, the

surface water drainage and the flow of groundwater. Discharging water to the surface or near-surface may accelerate the dissolution of limestone or dolomite and therefore activate the formation of sinkholes. Returning water to its original aquifer will tend to lessen this potential problem. However, in all cases the system installer should exercise caution when placing a GWHP over carbonate terrain (see Chapter 5 for commercial systems).

Man-induced subsidence often results in areas of deep mining. However, the transfer of groundwater to or from mine pools is likely to have little impact on the stability of mined areas. Most rocks (sandstone, shale, siltstone) associated with coal mining are not susceptible to dissolution by flowing groundwater. Subsidence can also occur from the dewatering of an aquifer.

4.7. ENVIRONMENTAL CONSIDERATIONS AND RECOMMENDATIONS

General recommendations are also presented in Chapter 5. The following recommendations are specific to open GSHP systems.

The yield, quality and temperature of the aquifer should be assessed before constructing the GWHP system. Lack of adequate flow may preclude a GWHP. Also, poor water quality could corrode or clog the system. The entering water temperature (EWT) will be a factor in the sizing of the heat pump system. All systems should be periodically inspected.

4.7.1. System with Return Well

Wells should be constructed in a manner to prevent groundwater degradation and to allow for production and disposal of the used groundwater. The return well should be used only for the injection of groundwater and should return it to the same aquifer from which it was taken. The return well must be able to accept the volume of groundwater to be discharged. No chemical additives may be used in the system.

4.7.2. System with Surface Return

Systems which demand high quantities of groundwater should be assessed to determine the GWHP system's effect on the surrounding area (see also Chapter 5 on commercial systems). Such an assessment might include:

- the proposed well spacing, water use and withdrawal amounts
- the effect on groundwater quality, quantity and temperature
- changes relative to adjacent land and water use
- the stability of bedrock and the effect of increased groundwater movement
- the precautions that will be taken to prevent aquifer drawdown and well interference
- future changes in water use
- water use planning

For systems that discharge to surface waters, discharge water temperatures must be consistent with existing regulations. A NPDES permit may be required for discharge to surface waters. The system installer should contact the appropriate DEP regional office.

Domestic users are not likely to impact an area's groundwater supply; however, non-consumptive systems are preferred.

4.7.3. Well Construction Recommendations

The following recommendations represent minimum guidelines for the construction of wells in GWHP systems. In addition, see "Guidelines for Installing Private Water Wells in Bedrock" on the DEP website at www.dep.state.pa.us, directLINK "private wells."

Siting Wells - Wells must be sited away from potential and existing sources of contamination and from other wells. Typically, at least 100 feet should separate the new well from features such as septic tanks, lagoons, livestock pens, storage tanks, etc. For land disposal sites or landfills, a considerably greater distance should be established.

Drilling - Acceptable methods of well drilling include rotary, cable tool and auger. Advantages and disadvantages of the various drilling methods are outlined in many hydrogeologic publications and texts. The selection of the method will be primarily up to the driller. However, the driller's method should be environmentally sound.

When a driller constructs a well, one of the primary concerns should be preventing the introduction or spread of contamination. The potential sources of contamination are numerous. They include hydraulic fluids or fuels from the rig, existing surface or subsurface contamination, underground utility lines or even airborne pollutants. The driller must construct the well to prevent the upward or downward migration of contamination. Accurate records should be kept for the borings and wells. The records should include the well location, depth, diameter, materials and construction, the dates of work and a geologic log.

Construction - Every well should be designed and constructed to ensure protection of the groundwater resources from sources of contamination. Wells should also be designed to conserve groundwater while providing an adequate and safe supply. The yield of the wells should be determined so that the owner may judge how adequate the well will be for the GWHP system.

Casing - Casing should be installed through the overburden of unconsolidated material and into solid material to prevent collapse of the hole and the migration of surface pollutants down along the side of the drill hole (see the following section on grouting).

The material used for casing should be strong enough to protect the well during construction and then for the anticipated life of the well. Pipe with thin walls or made of sheet metal should not be used. Contaminated casing should not be used.

Grouting - The main purpose in sealing the annular space between the surface casing and the drill hole is to prevent any surface contamination from moving down into the aquifer (see Section 3.8.2). It is recommended that the contractor place grout in the entire annular space between the surface casing and the drill hole.

A high solids bentonite or cement grout may be used (see Section 3.8.2.1). The grout can be placed by either gravity or by pumping. For wells deeper than 20-30 feet where the annular space cannot be seen to the bottom, the well should be grouted from the bottom to the surface by using a tremie pipe. Pelletized and coarse-grade bentonite also can form good seals. Recommendations for using this material are made in Section 3.8.2.2. Existing local regulations may require specific construction details.

5. Commercial GSHP Systems

GSHPs that are installed for schools, offices, apartment complexes or other large buildings are typically considered commercial systems. The smaller commercial systems are approximately 2 to 25 tons; large systems have ranged up to 1600 tons of cooling. Large buildings or complexes can be divided into different heating and cooling units that are all connected to the ground source loop. Different methods of heat storage can then be combined with the system so that the large GSHP system becomes a method of energy management.

5.1. TYPES OF SYSTEMS

Probably more than half of the existing commercial GSHP systems are vertical closed loop systems, although a few open loop systems have been installed in the Northeast. Commercial horizontal GSHP systems are being installed using coils in trenches or large excavated areas. Figure 4 shows two common configurations for commercial closed loop systems.

FIGURE 4. COMMERCIAL GSHP SYSTEMS
(not to scale)

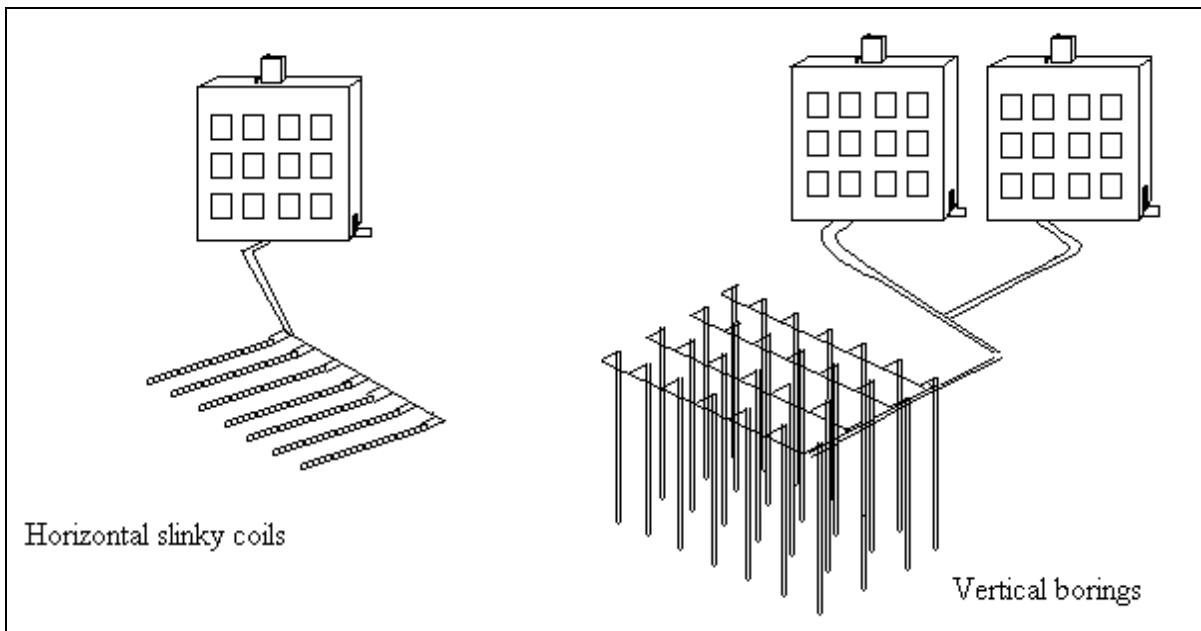

5.1.1. Horizontal Closed Loop

Horizontal closed loops are installed in trenches or large excavated areas. System installers often lay rows of coils to limit the amount of excavated area. Because of the space and excavation needed, the horizontal systems are generally used by the smaller commercial buildings.

5.1.2. Vertical Closed Loop GSHP Systems

Vertical closed loop systems use borings that are typically drilled to between 200 and 300 feet in depth. The number of borings depends on their depth and the size of the system. About 125 feet of boring is needed per ton of cooling. Therefore, the deeper the borings, the fewer borings are necessary. As examples of vertical loop systems, a 50-ton GSHP system would need over 20 300-foot borings; a 500-ton system might need 125 500-foot borings.

The area where the borings are located is sometimes referred to as the well field. The well field can be located underneath parking lots or in open fields or lawns. The heat exchanging pipes in the borings are connected to centralized manifold areas where they can be serviced or monitored.

The horizontal spacing between borings should be between 20 and 25 feet. The spacing must be able to handle the short and long term effects of the heating and cooling cycles.

5.1.3. Groundwater Heat Pumps

Commercial groundwater heat pumps use a large flow of groundwater past the heat pump. In this respect, the only difference in operation from a domestic GWHP is the amount of water required (see Chapter 4).

5.2. ENVIRONMENTAL CONCERNS

There are three main types of concerns associated with the installation and operation of a large volume GSHP systems. They include 1) water quality, 2) water quantity and 3) geologic hazards.

5.2.1. Water Quality

Water quality issues include 1) the potential leakage of the antifreeze solution, 2) the change of temperature of the subsurface and 3) contamination migration and turbidity effects associated with the installation of borings and trenches.

5.2.1.1. Leaks

For the antifreeze, few concerns go beyond the normal precautions of installation and operation. Although the amount of antifreeze can be much greater with commercial systems, proper installation using IGSHPA standards and non-toxic antifreezes will avoid concerns with the leaking of antifreeze into the environment. In addition, because the cooling process dominates (excess heat), antifreeze is often unneeded.

If a leak does occur in the ground loop, the pumps used to circulate antifreeze will typically shut down at the loss or drop of pressure. The connection of the pipe in the borings to headers allows for isolation of a problem area. Pressure checks before and after the placement of the antifreeze into the ground loop is another check on the system. Loss of toxic solutions into the subsurface may require remediation. See Section 5.3 on remediation requirements.

5.2.1.2. Thermal Changes

No long term, thermal imbalance occurs when the heating and cooling seasons are about the same. Depending on the building type, the regional climate and whether the cooling or heating cycle will dominate, a GSHP system will either cool or warm the subsurface until an equilibrium is reached. Consequences (thermal, chemical or biological) of this long-term heat gain or loss may need to be considered when nearby users could be affected.

5.2.1.3. Borings and Trench Installation

The installation of the borings, wells or trenches can be a cause for concern for the commercial GSHP systems. The use of borings and trenches is very unlikely to change the amount of groundwater available; however, borings and trenches can modify the quality of groundwater in two ways:

- by increasing the potential for movement of existing pollution or
- by disturbing the subsurface conditions

Contamination Migration – The increase in the potential for pollution migration can occur in different ways. The drilling process could allow existing polluted groundwater or surface water to spread from one area to another as the drilling proceeds. If the borings are not properly grouted, then polluted water (surface or groundwater) could use the borings as vertical routes to different areas of an aquifer or to different aquifers.

Trenches with gravel bases for the pipe could act as drains or conduits for contamination migration. The best method of preventing this is to avoid potential sources of contamination in the installation area.

Subsurface Disturbance – Disturbance of the subsurface can occur by drilling or by digging trenches. Drilling introduces or stirs up suspended solids or fines in the groundwater. Although most rock types will be unaffected from disturbances, a few types will be more susceptible to increased turbidity from drilling. Carbonate rocks such as limestone and dolomite are especially vulnerable to disturbances such as drilling or blasting. This is mainly because of its tendency to develop large fractures from the dissolving of the rock. The insoluble portion of the rocks is the source of the mud and turbidity in the groundwater. When the subsurface is disturbed, turbid groundwater can result.

Limestone and dolomite rocks very often contain sinkholes, solution channels and caverns. This is known as karst development, which is caused by the slightly acidic groundwater dissolving the rocks. In Pennsylvania, almost all carbonate rocks will show some karst characteristics, which can include rapid flow of groundwater.

Groundwater quality in these areas will often be subject to quick changes in turbidity because of a heavy rainfall or high water table conditions or from activities such as drilling or blasting. The installation of large diameter wells including the process of well development also may cause turbidity problems for nearby wells, especially those in carbonate rocks. Digging trenches also could affect turbidity conditions in the groundwater.

Turbidity may be a short-lived and minor problem; however, for a groundwater supply well it can be a serious problem, even if short-lived. In time, sudden turbidity problems should subside for rock formations where turbidity is not normally a persistent problem.

The grouting of borings or wells in the carbonate aquifers can be another problem. If a significant open space (from a cavern or large fracture) is hit during the drilling, it may be difficult or impossible to seal the boring. Various methods can be used to try to seal such a hole, but it may be expensive and cause localized contamination to the aquifer from the grout used. Poorly sealed borings or wells can possibly alter the flow conditions and cause turbid groundwater.

5.2.2. Quantity of Groundwater

Large open loop systems (GWHPs) are subject to the same concerns as listed in Section 4.6 and 4.7; however, commercially sized GWHPs will be dealing with much greater volumes of groundwater than domestic GWHPs. Systems that do not recharge the used water may affect groundwater availability for nearby wells. See Section 4.6.6 for a summary of the potential water supply problems of these types of systems.

5.2.3. Geologic Hazards

Sinkholes are the principal geologic hazard associated with the disturbance of the land surface. Trenches in carbonate areas may act as french drains that change the local subsurface drainage conditions and accelerate the formation of sinkholes. This could cause subsidence of the area around the ground loop or even around buildings.

A GSHP system that has a large number of poorly sealed borings can possibly alter the flow conditions and cause the collapse of dissolution features that have been slowly developing over the years. Changes in the surface drainage can accelerate the formation of sinkholes and other collapse features. Such changes also could damage the integrity of the GSHP system.

The removal of large quantities of groundwater for an open GSHP system can stimulate the formation of sinkholes. Although fewer problems should occur if the groundwater is reinjected, the wells still must be properly constructed to avoid down-hole erosion problems.

5.3. ENVIRONMENTAL CLEANUP

Accidental excavation of a ground loop area or an unstopped leak could allow antifreeze into the subsurface. Large spills into the ground are unlikely. However, cleanup of the solution may be necessary depending on the type of antifreeze, amount of fluid lost and the potential receptors. The release of biodegradable antifreeze solutions will typically require no remediation actions. The regional DEP office should be contacted.

5.4. RECOMMENDATIONS

Caution should be exercised for the installation of large commercial GSHP systems, especially in the known karst areas of the state. The geology of commercial GSHP system should be determined. If the system is to be located in a carbonate region, the contractor or installer should inspect the construction area for evidence of sinkholes. In some cases where there are a high density of sinkholes, it may be best to avoid putting in systems that require many borings or a large excavated area. The Bureau of Topographic and Geologic Survey should be consulted for information on sinkholes. The survey has mapped many of the concentrated sinkhole areas in Pennsylvania; open-file reports are available from the State Book Store (see Section 6.2).

The sheer number of borings used in some commercial, vertical GSHP systems makes the grouting procedure crucial. All borings should be carefully and completely grouted to keep the aquifer in the same condition as existed before the system was installed. Contractors excavating or drilling must contact the PA One Call system to check for underground utilities. (see Section 6.1).

Hydrogeological Studies and System Monitoring - Because of the potential problems with vertical closed loop and the open, large GSHP systems, it may be necessary to investigate their risks. In determining who is likely to be affected by the installation of the GSHP system, a hydrogeological investigation may be necessary. This is especially true for systems having over 10 borings or over 2,500 feet of borings and will be constructed in limestone or dolomite rocks (see Section 6.2 for information on how to determine the

geology of an area). Proposed GWHP systems that will withdraw (but not reinject) large volumes of groundwater may also be worth investigating before their installation.

Important questions for a hydrogeological study include:

- What are the main uses of the groundwater in the area?
- What is the geology of the area and how will it influence the GSHP installation and operation?
- What are the locations and numbers of groundwater users within a half mile radius of the GSHP system?
- If the system is to withdraw groundwater, what will be the withdrawal rate?
- Do users of the aquifer include municipal systems with wellhead protection programs?

Any necessary approvals should be obtained before starting the project. For closed-loop systems, no state permits are required. Local communities and governments may have restrictions and requirements for installations.

The use of monitoring wells is recommended for very large systems (hundreds of borings) that may affect the nearby users of groundwater. Monitoring also may be beneficial for systems that are very close to large municipal well supplies. Little research has been done on the effects of large systems that either add heat or take heat from the ground over the years. Changes in groundwater quality because of temperature changes likewise have been little researched.

Specific analytes to monitor for include temperature, pH, specific conductance, total dissolved solids and any other appropriate analyte such as bacteria. Knowing the background or ambient groundwater quality is important to be able to measure changes to the aquifer. This can be done by evaluating the groundwater quality upgradient of the system and by monitoring the groundwater before the system is started.

6. SUMMARY

6.1. GENERAL CONSIDERATIONS

There are two main types of GSHP systems: closed-loop systems and open systems. When proper installation practices are not followed, these systems have the capacity to cause groundwater problems in the following ways:

- GSHP fluids could escape and migrate to the groundwater.
- Improperly constructed wells or borings could serve as channels of contamination from the surface to the subsurface or from one aquifer to another.
- GWHPs could affect a groundwater supply.
- Changes in drainage could cause subsidence problems.

Because of these potential problems, care should be taken during and after installation to avoid unnecessary environmental risks. In addition to the recommendations in Sections 3.8, 4.6, and 5.4, the following general practices and procedures are recommended:

GSHP Systems

- All work should be performed by professional installers, contractors and licensed drillers.
- Contractors must check for underground utilities before excavating trenches or drilling holes. The Pennsylvania One Call System will notify all utility companies that might have buried utilities in the excavation area. Pennsylvania law requires that a three working-day notice be given prior to the disturbance of the earth by any powered equipment. The toll-free telephone number is 1-800-242-1776 (www.paonecall.org).
- A record should be made of the locations and construction details of the underground components of GSHP systems; the record should include a site map that details the system layout and distances from landmarks such as property lines and buildings.
- Potable water should be used in all drilling, grouting and cleanup operations.
- A restoration agreement should be developed between the system installer and owner for the repair of any problem that occurs after installation of the GSHP system.
- The installer should adhere to standards of the IGSHPA.
- The system operator should monitor and periodically inspect the aboveground portions of the system (including filter and pressure checks) since slight changes may be a precursor to problems.
- The heat pump system should have an automatic shutdown device to prevent refrigerant or oil leaks from migrating.

Closed Systems

- The system installer should place short iron stakes or metallic tape over appropriate areas (like the end of a closed-loop trench or a buried manifold section) to guide any future worker who needs to excavate a portion of the system.
- An identification tag for the antifreeze solution should be attached in a obvious place; the tag should list the type of fluid, its concentration and volume.

Open Systems

- Open system wells should be constructed properly in accordance with the 1998 National Ground Water Association "Manual of Water Well Construction Practices," DEP guidelines and any appropriate state and local codes and guidelines.
- The contractor should install a backflow device ahead of the heat pump unit to protect the supply well (if used) from contamination.

Large Volume, Commercial Systems

- Hydrogeological studies should be considered where carbonate geology exists.
- Systems with tens or hundreds of borings should generally avoid carbonate areas unless studies indicate solid bedrock with few karst problems.
- Monitoring wells should be considered where a system could affect nearby users of groundwater.

Operational and environmental advantages and disadvantages of different GSHP systems are summarized in Table 3.

6.2. ADDITIONAL SOURCES OF INFORMATION

The following references are additional sources of information on the different aspects of GSHP system design and installation. Also, the local public utility commission, the United States Geological Survey, and the library may be other sources of information and assistance.

Department of Environmental Protection
Bureau of Watershed Management
P.O. Box 8555

Harrisburg, PA 17105-8555

Telephone: 717-787-5259

website: www.dep.state.pa.us Subject: Groundwater protection. DirectLINK: "private wells"

Selected Publications:

- ◆ Ground Source Heat Pumps Fact Sheet, 2000, 3900-FS-DEP2006
- ◆ Guidelines for Installing Private Water Wells in Bedrock, 2000, 3800-FS-DEP2450

Geology of Pennsylvania:

Pennsylvania Department of Conservation and Natural Resources
Bureau of Topographic and Geologic Survey
P.O. Box 8453
Harrisburg, PA 17105-8453
(Telephone: 717-787-5828)
website: www.dcnr.state.pa.us/topogeo

Selected Publications:

- ◆ The Geology of Pennsylvania's Groundwater, 1999
- ◆ The Geology of Pennsylvania, 1999
- ◆ Geologic Map of Pennsylvania, 1980
- ◆ Atlas of Preliminary Geologic Quadrangle Maps of Pennsylvania, Map 61, 1981
- ◆ Engineering Characteristics of the Rocks of Pennsylvania, EG-1, 1982

These publications can be purchased from the Department of General Services, State Book Store, 1825 Stanley Drive, Harrisburg, PA, 17103, 717-787-5109.

TABLE 3. ADVANTAGES AND DISADVANTAGES OF GSHP SYSTEMS

SYSTEM	ADVANTAGES	DISADVANTAGES
Closed-Loop	<ul style="list-style-type: none"> • Avoids problems such as: chemical reactions with groundwater, corrosion, scaling, aquifer drawdown • Can be used where ground water is too deep or in short supply • Can be isolated from the potable water supply • Can be used in a small area of land (vertical loop) • Low maintenance 	<ul style="list-style-type: none"> • Vertical loops require borings or wells • Loops can potentially rupture and lose fluids • Some antifreeze fluids are toxic and/or corrosive • Horizontal loops require excavation
Direct Exchange Loop	<ul style="list-style-type: none"> • Can be very efficient in moist, sandy soils. 	<ul style="list-style-type: none"> • Requires large volume of refrigerant • Refrigerant loop may bake clayey soils and reduce efficiency of system • Copper pipes can be susceptible to corrosion
Open System with return well to same aquifer	<ul style="list-style-type: none"> • No net loss of groundwater • Groundwater temperatures kept steady 	<ul style="list-style-type: none"> • Drilling costs for two wells • Return well may clog • Well/pump maintenance • Need adequate water supply
Open System with surface disposal of groundwater	<ul style="list-style-type: none"> • Inexpensive • Minor maintenance 	<ul style="list-style-type: none"> • NPDES permit may be necessary for disposal to surface water bodies • Little conservation of water • Possible maintenance of water disposal method • May impact aquatic life
Commercial Systems	<ul style="list-style-type: none"> • Economic savings • Minor maintenance 	<ul style="list-style-type: none"> • Could cause problems in carbonate areas • Long term thermal effects unknown

Ground Source Heat Pump Systems:

International Ground Source Heat Pump Association
499 Cordell South
Oklahoma State University
Stillwater, OK 74078-8018
(Telephone: 800-626-4747)
website: www.igshpa.okstate.edu

Selected Publications:

- ◆ Ground Source Systems - Design and Installation Standards, IGSHPA
- ◆ Closed-Loop/Ground Source Heat Pump Systems – Installation Guide, 1988
- ◆ Soil and Rock Classification for the Design of Ground-Coupled Heat Pump Systems – Field Manual, Electric Power Research Institute, 1989
- ◆ Grouting Procedures for Ground-Source Heat Pump Systems, IGSHPA, 1991

National Ground Water Association
601 Dempsey Road
Westerville, OH 43081
(Telephone: 614-898-7791)
website: www.ngwa.org

Selected Publications:

- ◆ Ground Water Heat Pump Anthology - Third Edition, May 1991
- ◆ Manual of Water Well Construction Practices - Second Edition, 1998

American Society of Heating, Refrigerating and Air-Conditioning Engineers (ASHRAE)
1791 Tullie Circle NE
Atlanta, GA 30329
(Telephone: 800-527-4723)
website: www.ashrae.org

Selected Publications:

- ◆ Commercial/Institutional Ground Source Heat Pump Engineering Manual, 1995, 200 pp.; covers commercial GSHP systems (>15,000 square feet) with appendixes.

Other Organizations

Electric Power Research Institute
3412 Hillview Avenue
Palo Alto, CA 94304
(Telephone: 415-855-2411)
website: www.epri.com

Geothermal Heat Pump Consortium, Inc.
701 Pennsylvania Ave., N.W.
Washington, DC 20004-2696
(Telephone: 202-508-5500)
website: www.geoexchange.org

Interstate River Basin Commissions:

Ohio River Valley Water Sanitation Commission
5735 Kellogg Avenue
Cincinnati, OH 45228-1112
(Telephone: 513-231-7719)
website: www.orsanco.org

Delaware River Basin Commission
P.O. Box 7630
West Trenton, NJ 08628-0360
(Telephone: 609-883-9500)
website: state.nj.us/drbc

Interstate Commission of the Potomac
Suite 300, 6110 Executive Boulevard
Rockville, MD 20852-3903
(Telephone: 301-984-1908)
website: www.potomacriver.org

Susquehanna River Basin Commission
1721 N. Front Street
Harrisburg, PA 17102
(Telephone: 717-238-0423)
website: www.srbc.net

U.S. ENVIRONMENTAL PROTECTION AGENCY

Information regarding injection wells for groundwater heat pumps should be obtained from the EPA at the following address:

U.S. EPA Region III
Office of Ground Water, 3WP32
1650 Arch Street
Philadelphia, PA 19103-2029
(Telephone: 215-814-5445)
website: ww.epa.gov/region3

6.3. REFERENCES

THE CLEAN STREAMS LAW, the Act of June 22, 1937 (P.L. 1937, No. 394), as amended, 35 P.S. 691.1 *et seq.*

THE CLEAN WATER ACT (33 U.S.C. 1251 *et seq.*)

DRISCOLL, F. G. 1986. Groundwater and Wells, Second Edition. Johnson Division, St. Paul, MN. 1089 pp.

ELECTRIC POWER RESEARCH INSTITUTE. 1989. Soil and Rock Classification for the Design of Ground-Coupled Heat Pump Systems - Field Manual. Distributed by International Ground Source Heat Pump Association. 79 pp.

ELECTRIC POWER RESEARCH INSTITUTE. 1992. Ground-Source Heat Pumps. 6 pp.

FREEZE, R. A. and J.A. CHERRY. 1979. Groundwater. Prentice-Hall, Inc., Englewood Cliffs, NJ. 604 pp.

INDIANA STATE BOARD OF HEALTH. 1984. Standards for Construction of Geothermal Heat Pump Systems. Bulletin PWS 5. 19 pp.

INTERNATIONAL GROUND SOURCE HEAT PUMP ASSOCIATION. Ground Source Systems Design and Installation Standards. Oklahoma State University. 9 pp.

INTERNATIONAL GROUND SOURCE HEAT PUMP ASSOCIATION. 1988. Closed-Loop/Ground Source Heat Pump Systems - Installation Guide. Oklahoma State University. 236 pp.

- KAVANAUGH, S. P. AND K. RAFFERTY. 1997. Ground Source Heat Pumps: Design of Geothermal Systems for Commercial and Institutional Buildings. ASHRAE.
- KAVANAUGH, S. P. October 1998. Simple, Efficient, Reliable: Ground Source Heat Pumps. ASHRAE Journal Online.
- INTERNATIONAL GROUND SOURCE HEAT PUMP ASSOCIATION. 1991. Grouting Procedures for Ground-Source Heat Pump Systems. Oklahoma State University. 45 pp.
- MCCRAY, K.B. June 1998. Drilling Vertical Boreholes For Closed Loop Heat Pump Systems. Water Well Journal, pp 48-50.
- MICHIGAN DEPARTMENT OF PUBLIC HEALTH. March 1982. Ground Water Heat Pump Installations in Michigan. Michigan Department of Public Health, Lansing, MI. 28 pp.
- MICHIGAN DEPARTMENT OF PUBLIC HEALTH. January 1988. Michigan Water Well Grouting Manual. Michigan Department of Public Health, Lansing, MI. 83 pp.
- NATIONAL GROUND WATER ASSOCIATION. May 1991. Ground Water Heat Pump Anthology: Third Edition. National Ground Water Association. 24 papers.
- PENNSYLVANIA DEPARTMENT OF ENVIRONMENTAL PROTECTION. October 1976. Ground Water Law in Pennsylvania.
- PENNSYLVANIA DEPARTMENT OF ENVIRONMENTAL PROTECTION. January 1992. 1st edition. Special Protection Waters Implementation Handbook.
- RIEWE, T. September 1995. Grouting with the Ohio Recipe in Wisconsin. Water Well Journal. pp 35-37.
- SWANSON, G. J. April 1999. Thermally Enhanced Grout: What it is and How it works. Water Well Journal. pp 37-40.
- TENNESSEE VALLEY AUTHORITY. 1986. Geothermal Heating and Cooling Installation Manual. 52 pp.
- U.S. DEPARTMENT OF ENERGY. January 1981. Environmental Assessment - Aquifer Thermal Energy Storage Program. Washington, D.C. 41 pp.
- U.S. DEPARTMENT OF ENERGY. December 1983. Using the Earth to Heat and Cool Homes. U.S. Government Printing Office, Washington, D.C. 22 pp.
- U.S. ENVIRONMENTAL PROTECTION AGENCY. April 1993. Space Conditioning: The Next Frontier. The Potential of Advanced Residential Space Conditioning Technologies for Reducing Pollution and Saving Consumers Money. 430-R-93-004.
- U.S. GENERAL ACCOUNTING OFFICE. June 1994. Geothermal Energy: Outlook Limited for Some Uses but Promising for Geothermal Heat Pumps, 80 pp.

Appendix

DEP REGIONAL OFFICES

Region	Region Headquarters	Counties Supervised
Southeast	Suite 6010 Lee Park 555 North Lane Conshohocken, PA 19428 Phone: 610-832-6059	*Bucks, *Chester, Delaware, Montgomery, Philadelphia
Northeast	2 Public Square Wilkes-Barre, PA 18711-0790 Phone: 570-826-2511	Carbon, Lackawanna, Lehigh, Luzerne, Monroe, Northampton, Pike, Schuylkill, Susquehanna, Wayne, Wyoming
Southcentral	909 Elmerton Ave. Harrisburg, PA 17110 Phone: 717-705-4708	Adams, Bedford, Berks, Blair, Cumberland, Dauphin, Franklin, Fulton, Huntingdon, Juniata, Lancaster, Lebanon, Mifflin, Perry, York
Northcentral	208 W. Third St., Suite 101 Williamsport, PA 17701 Phone: 570-327-3675	Bradford, Cameron, Centre, Clearfield, Clinton, Columbia, Lycoming, Montour, Northumberland, Potter, Snyder, Sullivan, Tioga, Union
Southwest	400 Waterfront Drive Pittsburgh, PA 15222-4745 Phone: 412-442-4217	*Allegheny, Armstrong, Beaver, Cambria, Fayette, Greene, Indiana, Somerset, Washington, Westmoreland
Northwest	230 Chestnut St. Meadville, PA 16335-3481 Phone: 814-332-6899	Butler, Clarion, Crawford, Elk, *Erie, Forest, Jefferson, Lawrence, McKean, Mercer, Venango, Warren

*County Health Departments

This and related environmental information are available electronically via Internet. For more information, visit us through the PA PowerPort at <http://www.state.pa.us> or visit DEP directly at <http://www.dep.state.pa.us> (directLINK "Drinking Water Publications").



www.GreenWorks.tv - A web space dedicated to helping you learn how to protect and improve the environment. The site features the largest collection of environmental videos available on the Internet and is produced by the nonprofit Environmental Fund for Pennsylvania, with financial support from the Pennsylvania Department of Environmental Protection, 877-PA-GREEN.

*Bureau of Watershed Management
P.O. Box 8555
Harrisburg, PA 17105-8555*

383-0300-001

Equal Opportunity Employer



Printed on Recycled Paper